

Service Manual

SMARTDRIVE Electronic Washer



care

The specifications and servicing procedures outlined in this manual are subject to change without notice.

The latest version is indicated by the reprint date and replaces any earlier editions. -

Fisher & Paykel Appliances Ltd
78 Springs Road,
East Tamaki,
PO Box 58546, Botany,
Manukau, 2163
Auckland,
New Zealand
Phone: 09 273 0600
Fax: 09 273 0656
Email: customer.care@fp.co.nz

Fisher & Paykel Customer Services Pty Ltd
PO Box 798, Cleveland, QLD 4163
A.C.N. 003 3335 171
19 Enterprise Street
Cleveland, QLD 4163
Australia
Telephone: (07) 3826 9100
Facsimile: (07) 3826 9164
Email: : customer.care@fp.com.au

Fisher & Paykel Singapore Pte Ltd
150 Ubi Avenue 4
Sunlight Building #02-00
Singapore 408825
Telephone: 65 65470100
Facsimile: 65 65470123

FISHER & PAYKEL



ELECTRONIC WASHING MACHINES

Covering the following Models

New Zealand

Australia & New Zealand

Rest of World

Model	CA	Model	CA	Model	CA
MW613	92144	MW513	92145	WA55T56MW	94145 HK
MW613	92112	MW513	92103		
		WA55T56G	93177	WA75T56GW	94177 HK
		WA55T56G	92109		
		WA70T60G	92146	WA85T60GW	94146 HK
		WA70T60G	92129		
		WA80T65G	92193	WA10T65GW	94193 HK
		WA80T65G	92133		
		WA70T60F	92158	WA85T60F	94189 HK
		WA70T60F	92132	WA85T60F	95189 IN
		WA80T65F	92159	WA10T65F	94162 HK
		WA80T65F	92135	WA10T65F	94163 IN







CONTENTS

1	HEALTH & SAFETY	6
2	SPECIFICATIONS	7
2.1	Dimensions	7
2.2	Maximum Capacity (Full Load)	7
2.3	Water Consumption	7
2.4	Water Fill Temperature (Approximate Factory Settings).....	7
2.5	Wash Motor.....	7
2.6	Pump Motor	8
2.7	Water Valves.....	8
2.8	Diverter Valve	8
2.9	Thermistor.....	8
2.10	Cabinet.....	8
2.11	Lid	8
2.12	Top Deck.....	8
2.13	Inner Bowl	9
2.14	Outer Bowl	9
2.15	Console.....	9
2.16	Agitator.....	9
2.17	Fabric Softener Dispenser	9
2.18	Electric Supply	9
2.19	User Information	9
2.20	Lid Lock.....	9
2.21	Control Panel FabricSmart– (IW).....	10
2.22	Control Panel WashSmart– (GW & WA).....	10
2.23	Control Panel QuickSmart– (MW).....	10
2.24	Important Screw / Bolt Torque Settings	10
3	TECHNICAL OVERVIEW	11
3.1	Electronics	11
3.2	Stand By Mode	12
3.3	Out of Balance Detection – ‘Bump Detect’	12
3.4	Water Temperature Sensing.....	13
3.5	Water Valves.....	15
3.6	Diverter Valve (FabricSmart, IW Only).....	16
3.7	Water Level Measurement.....	16
3.8	Motor.....	18
3.9	Pumps.....	20
3.10	Lid Lock.....	20
3.11	Inner Bowl and Outer Bowl	21
3.12	Agitator.....	22
3.13	Lint Removal System	23
3.14	Fabric Softener Dispensing.....	24
4	SIZE SETTING MODE	25
4.1	QuickSmart, WashSmart, MW, GW & WA Size setting	25
4.2	FabricSmart IW Size setting	26
5	DIAGNOSTIC MODE	26
5.1	QuickSmart, WashSmart, MW, GW and WA Models.....	26
5.2	FabricSmart, IW (intuitive)	28
5.3	Control Screen	31
5.4	Data Download	33
5.5	Showroom Mode.....	33
5.6	User Warnings QuickSmart WashSmart MW, GW & WA.....	34
5.7	Diagnostic Table QuickSmart, WashSmart, MW, GW & WA Models	37
5.8	Voltage Readings from the Controller.....	39
5.9	Resistance Readings from the Controller	40
5.10	Binary Decoding Chart – 8 Bits (0-255) QuickSmart, WashSmart, MW, GW & WA	41
6	WIRING DIAGRAM.....	42

7	DETAILED FAULT CODES.....	43
7.1	Fault Descriptions	43
8	SERVICE PROCEDURES	54
8.1	Removal of Lid.....	54
8.2	Components in Console Area.....	54
8.3	Removal of Display Module QuickSmart, WashSmart, MW, GW & WA.....	54
8.4	Removal of Display Module FabricSmart IW	55
8.5	Removal of Water Valves	55
8.6	Removal of Recirculating Valve.....	55
8.7	Removal of Thermistor	56
8.8	Removal of Motor Control Module	56
8.9	Removal of Cord Set	57
8.10	Removal of Lid Lock	57
8.11	Removal of Top Deck.....	58
8.12	Removal of Neck Ring.....	58
8.13	Removal of Agitator	58
8.14	Removal of Inner Bowl.....	59
8.15	Removal of Clutch Mechanism (Spline Drive / Spline Driven).....	59
8.16	Removal of Selni Pump Hood & Cap.....	59
8.17	Removal of Hanning Pump Hood	60
8.18	Removal of Outer Bowl from the Cabinet	60
8.19	Removal of Rotor.....	61
8.20	Removal of Stator	61
8.21	Removal of Pump	62
9	SPECIALISED SERVICE PROCEDURES	64
9.1	Blocked Pump Procedure Selni	64
9.2	Blocked Pump Procedure Hanning.....	65
9.3	Shaft & Bearing Replacement	66
9.4	Shaft & Bearing Assembly	68
10	WASH PERFORMANCE INFORMATION.....	70
10.1	Creasing	70
10.2	Soiling	70
10.3	Linting	70
10.4	Detergent Residue.....	70
10.5	Black Marks on Clothes	70
10.6	Grey Marks on Clothes	70
10.7	Dye Transfer	70
10.8	Tangling	70
11	OPERATING PROBLEMS	71
11.1	No Power	71
11.2	Flooding / Leaking	71
11.3	Noisy.....	71
11.4	Continuous or Slow Spinning.....	72
11.5	Siphoning.....	72

1 HEALTH & SAFETY

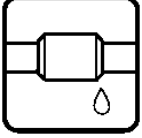
When servicing the Designer series Range Hood, health & Safety issues must be considered at all times. Specific safety issues are listed below with the appropriate icon.

	<p>Electrical Safety Ensure the mains power has been disconnected before servicing the washer. If the mains supply is required to be on to service the washer, make sure it is turned off when removing any electrical component or connection to avoid electric shock.</p>
	<p>Electrostatic Discharge An anti-static strap is to be used as electrical static discharge (ESD) protection when servicing electronic components.</p>
	<p>Good Working practices Ensure the work area is in a tidy and orderly condition at all times so as not to cause a hazard while service work is being completed. Always clean and tidy the washer and work area after service is completed.</p>
	<p>Isolate Water Supply Turn off the water connection taps before servicing</p>
	<p>Water Leak Check Check for water leaks as part of the testing after the service has been completed.</p>
	<p>Insulation test Megger test to check insulation Warning: short together the phase and neutral pins on the plug so not to damage any electronic circuitry.</p>
	<p>Sharp Metal Edges When working around cut sheet metal edges, use appropriate gloves or protection to eliminate the chance of receiving a laceration.</p>

2 SPECIFICATIONS

2.1 Dimensions

	Compact Washer	Medium Washer	Large Washer	
Height to lid	Open	1320mm – 1350 mm	1360mm – 1390 mm	1410mm – 1440mm
	Closed	950 mm – 980 mm	950 mm – 980 mm	950mm – 980mm
Height to console	1010 mm – 1050 mm	1010 mm – 1050 mm	1010mm – 1050mm	
Width	560 mm	600 mm	650mm	
Depth	560 mm	600 mm	650mm	
Inlet hose length	1200 mm	1200 mm	1200mm	
Packed weight	50.4 kg	55.3 kg	60.5	
Unpacked weight	43.5 kg	47.7kg	52.0	

Note: Exact height of the machine is dependent on how far the feet are inserted into the base of the machine.

2.2 Maximum Capacity (Full Load)

	Compact Washer	Medium Washer	Large Washer
Dry Weight	5.5kg	7kg	8kg

2.3 Water Consumption

***Note:** Approximate consumption for a high water level load for each rinse option offered.

	Compact Washer	Medium Washer	Large Washer
Full (High)	65 litres	75 litres	90 litres
Spray & Deep Rinse	130 litres	150 litres	175 litres
Save Water	110 litres	130 litres	150 litres
Eco Rinse	73 litres	90 litres	105 litres
1 Deep Rinse	120 litres	140 litres	165 litres
2 Deep Rinse	160 litres	190 litres	215 litres

2.4 Water Fill Temperature (Approximate Factory Settings)

	MW Washer		GW Washer
Supply	Water Fill Temp	Supply	Water Fill Temp
Hot	Supply temperature	Hot	60 °C
Warm	36 - 38°C*	Hot / Warm	50 °C
Cold	Supply temperature	Warm	40 °C
		Warm / Cold	35 °C
		Cold Plus	20 °C
		Cold	Supply temperature

Recommended hot water inlet temperature 70 °C (Max)

2.5 Wash Motor

Electronically commutated 36 pole direct drive 3 Phase brushless DC motor.
 Motor Resistance: 19.5Ω +/- 10% @ 20°C (39Ω +/- 3.95Ω across any two phases)

421827

2.6 Pump Motor

Part Number	Voltage	Frequency	Resistance	Type
420324P	230V AC	50Hz	33Ω +/- 8% @ 20°C	Selni
421820P	230V AC	50Hz	93Ω +/- 8% @ 20°C	Hanning

Note: Thermal cut-out fitted

2.7 Water Valves

Supply	Mode of Operation	Voltage	Resistance	Flow Rate
Cold	Digitally Operated	24V DC	64Ω @ 20°C	16 litres per minute
Hot	Digitally Operated	24VDC	64Ω @ 20°C	10 litres per minute

Note: Flow rate will vary slightly depending on pressure.

Operating pressures: Maximum 150psi / 1034 kPa - Minimum 5psi / 34 kPa

Note: Pressures below 5psi / 34kPa can create seating problems with the internal diaphragm of the valve, and may cause water to drip into the inner bowl when the machine is not in use.

2.8 Diverter Valve

Supply	Mode of Operation	Voltage	Resistance
Recirculates	Wax Solenoid	160V DC	1.7KΩ @ 68°F / 20°C

2.9 Thermistor

NTC-type temperature sensor (Thermistor) Resistance 10KΩ @ 77°F / 25°C

2.10 Cabinet

Pre-painted steel

2.11 Lid

ABS plastic (Co-Injected)

2.12 Top Deck

Polypropylene

2.13 Inner Bowl

Stainless steel: Grade 430T

Bowl base and balance ring: Polypropylene

The inner bowl on the large machine has a series of small bumps around the base of the inner bowl. These bumps are designed to improve wash performance by increasing load turnover and movement.

Note: The inner bowl is backwardly compatible with all SmartDrive machines.



Inner Bowl Weight

Large	10.48kg +/- 275g
Medium	8.37kg +/- 225g
Compact	7.30kg +/- 225g

Inner Bowl Speed	Heavy Duty	Regular	Easy Iron	Allergy	Hand Wash
Fast Spin	1,000 RPM	1,000 RPM	N/A	1,000 RPM	1,000 RPM
Medium Spin	670 RPM	670 RPM	N/A	670 RPM	670 RPM
Slow Spin	330 RPM	330 RPM	330 RPM	330 RPM	3300 RPM
Stir Speed	25 RPM	25 RPM	25 RPM	25 RPM	25 RPM

2.14 Outer Bowl

Aluminium insert over-moulded with polypropylene

2.15 Console

ABS plastic with ABS plastic insert for display module.

2.16 Agitator

Polypropylene

2.17 Fabric Softener Dispenser

Dosage 75cc

2.18 Electric Supply

Operating Voltage 220/240V AC 50Hz
Maximum Current 2.8 amps

2.19 User Information

User Guide 421384
424120

2.20 Lid Lock

Resistance 63Ω +/- 10% @ 68°F / 20°C

Note: Normally low voltage, potentially 230V if harness is grounded on the cabinet!

2.21 Control Panel FabricSmart– (IW)



2.22 Control Panel WashSmart– (GW & WA)



2.23 Control Panel QuickSmart– (MW)

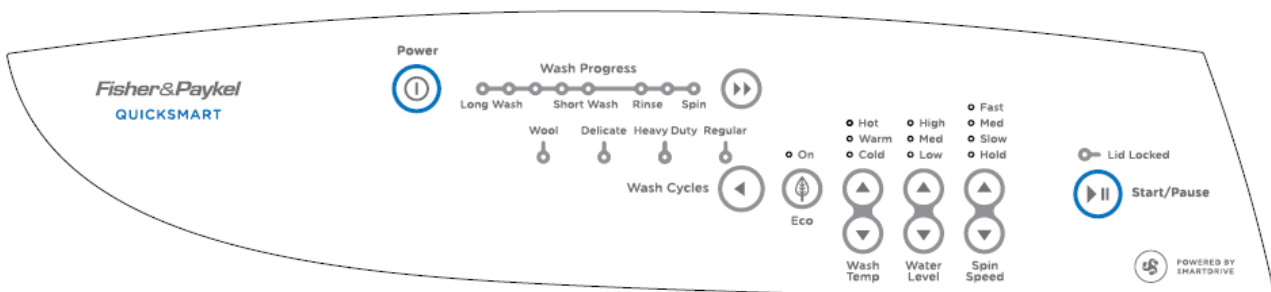

2.24 Important Screw / Bolt Torque Settings

Below are the important screw torque settings for SmartDrive™ washers. These settings must be adhered to. For all other screws and bolts that are not listed, we recommended that they are tightened sufficiently without being over-tightened.

Screw / Bolt	Torque (Nm)
Pump hood to cap to outer bowl	3Nm
Rotor bolt to shaft	8Nm
Nut Bearing to Shaft	18Nm
Stator to Outer bowl	5Nm
Nut Agitator to Shaft	4Nm
Spline Driven to Inner Bowl Base	1.5Nm
Nozzle Inlet to Top Deck	0.4Nm
Bracket Pump to Outer Bowl	3Nm

3 TECHNICAL OVERVIEW

This Service Manual contains information on the Product Specifications, Diagnostic Mode, Detailed Fault Codes and the complete disassembly and assembly instructions for the washing machine.

3.1 Electronics

3.1.1 Motor Control Module

The Motor Control microprocessor performs a wide variety of tasks. Primarily it controls the electronic switching hardware to control the three phase currents in the Smart Drive DC motor. The micro can accurately control not only the velocity of the motor but also the acceleration. This accurate control is required to perform all the different agitator profiles, or wash actions, that are used for caring for clothes. The Motor Control module performs the functions of fill, wash, drain spray rinse and spin, when commanded to by the Display.

The Motor Control module microprocessor has a wide range of control with great accuracy over water level, fill temperature, agitate action and spin speed. Having such control insures the wash cycle selected provides the optimum soil removal combined with appropriate gentleness for the washing and care of the clothes load.

The Motor Control Module for this Washer is air-cooled.

This Motor Control Module is **not inter-changeable** with other any other Series of machine.

Identification

The Motor Control module has an identification label attached to the top of the housing stating P9NECO (Phase 9, Conventional Pump Non Eco) and P9ECO (Phase 9, Conventional Pump Eco)

Motor Control Module



Note: When replacing a Motor Control Module ensure that the pressure tube is clear of any water droplets before operating the machine on a fill cycle. If the bowl is full of water drain the water then blow down the tube before reconnecting the pressure tube.

Ensure you have checked the resistance of all components going to the controller such as pump, water valves, etc. otherwise controller will short and fail.

3.1.2 Display Module

The Display Module provides the link between the washing machine electronics and the user. Input on wash type, water level, spin speed, start/stop and wash cycle time is given by the user via the display push buttons.

Feedback on selection is given to the user by LCD liquid crystal displays or Light Emitting Diodes (LEDs) depending on model. Sound effects accompany button presses.

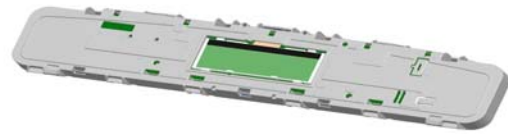

IW Display

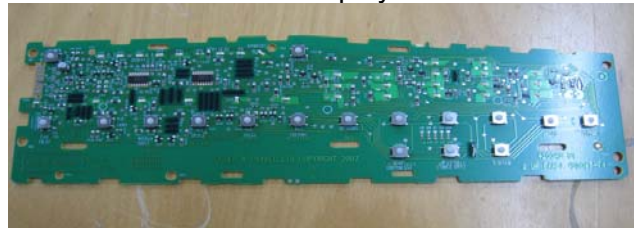

GW / WA & MW Display

3.2 Stand By Mode

If the machine has not received any instructions it will automatically go into a low power “Stand By” mode. The control panel will be blank as if it was powered off at the wall. “Stand By” happens after a period of 10 minutes for MW, GW & WA machines and 2 minutes for the IW.

Before entering the Diagnostic or Option Adjustment modes, the machine must be taken out of the Stand-By mode. To do this, the **POWER** button will have to be pressed, or the machine turned off and back on at the mains supply point.

3.3 Out of Balance Detection – ‘Bump Detect’

On this machine the Out of Balance detection, is undertaken with electronic sensing, known as ‘Bump Detect’. ‘Bump Detect’ is software written into the Motor Control Module, which looks at specific feedback from the Motor.

No fault codes are associated with ‘Bump Detect’, and there are no hard and fast tests that can be carried out.

If a machine continually goes into an out of balance condition then the following needs checking in the order given.

1. Even distribution of the wash load.
2. Ensure that the corner caps are clear of the floor & machine is sitting on its feet.
3. Ensure that the machine is both level and stable on the floor with feet inserts fitted.
4. Check the bias spring is fitted and attached.
5. Check the weight of the inner bowl. Bowl weights are as follows:
 - Compact: 7.30kg +/- 225g
 - Medium: 8.37kg +/- 225g
 - Large: 10.48kg +/- 275g.

Note: If the OOB problem persists after checking the above, we would then recommend replacing both the suspension rods and the rotor. It is highly unlikely that the Motor Control Module will be the cause.

3.4 Water Temperature Sensing

WashSmart, GW, WA & FabricSmart, IW Machines

The thermistor for sensing water temperature is located in the back of the outlet elbow on the valve assembly, and is connected directly to the Motor Control Module.

For details on the wash temperature adjustment Refer to the Use & Care manual.

Specifications

NTC-type temperature sensor (Thermistor)
Resistance 10K Ω @ 25°C.

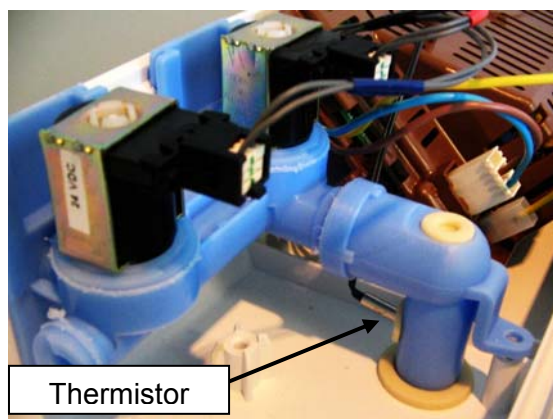

QuickSmart, MW Machines

As there is no thermistor (temperature sensor) in this Washer the only temperature that can be adjusted is the warm wash temperature. The temperature of the warm wash is entirely dependent on a number of factors:

- a. Cold water temperature
- b. Cold water pressure
- c. Hot water temperature
- d. Hot water pressure.
- e. Warm wash setting.

As the above will vary from installation to installation it would be impossible to predict what temperature each installation will ultimately achieve.

However under the conditions outlined below, a temperature of between 36–38°C should be achieved.

Cold water temperature: 20 °C

Cold water pressure: 320 kPa (46.5 psi)

Hot water temperature: 60 °C

Hot water pressure: 320 kPa (46.5 psi)

Warm wash setting: Default setting (9 min wash LED – 3rd Green wash LED from the left).

3.4.1 Warm Wash Temperature Adjustment (QuickSmart MW Only)

The warm wash temperature adjustment will alter the amount of time that the hot valve pulses on and off for.

1. Turn the machine on at the wall but off at the console.
2. Press and hold down the **START/PAUSE** button, then press the **POWER**. Two quick beeps will be heard and the machine will show an unusual pattern of lights. In this mode the lights are used to indicate the different options available.
3. Select the Warm Wash Temperature.
4. Advancing the Wash Progress LED by pressing the **ADVANCE** button will increase the wash temperature. If the **ADVANCE** button is continually pressed, the light will scroll back to the coldest setting available for that wash temperature.
5. Press the **POWER** to 'lock' in the setting.

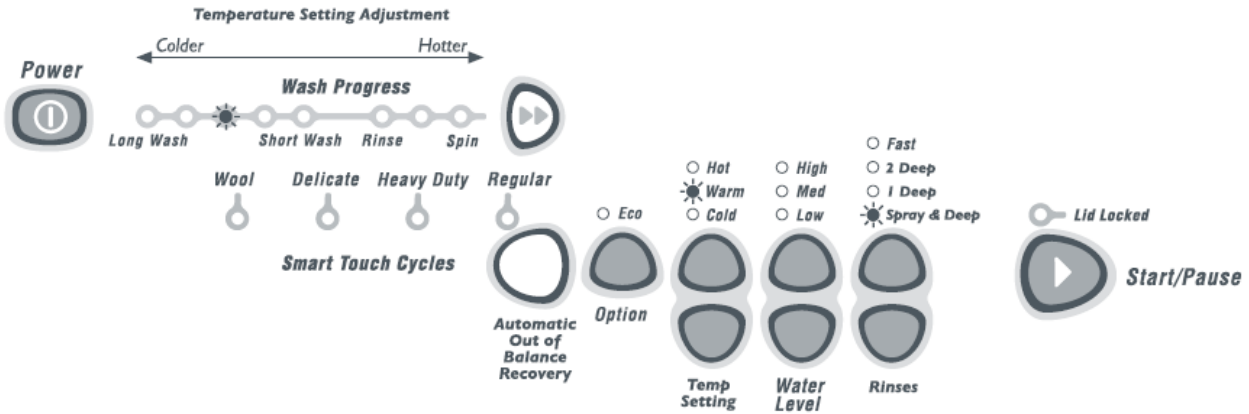

Note:

If the required temperature still can't be obtained, advance the wash progress LED (as described in the procedure above) across to the spin LED and manually adjust the flow of the taps.

3.4.2 Wash Temperature Adjustment (WashSmart, WA Only)

1. Turn the machine on at the wall but of at the console.
2. Press and hold down the **START/PAUSE** button, then press the **POWER**. Two quick beeps will be heard and the machine will show an unusual pattern of lights. In this mode the lights are used to indicate the different options available.
3. Use the **Wash Temp** buttons to select the **WASH TEMPERATURE** to be adjusted.
4. The wash progress lights show the temperature adjustment possible for that temperature. Pressing the **ADVANCE** will cause the wash progress light that is on to change. Advancing the Wash Progress light will increase the wash temperature. If the **ADVANCE** button is kept pressed, the light will scroll back to the coldest setting available for that wash temperature

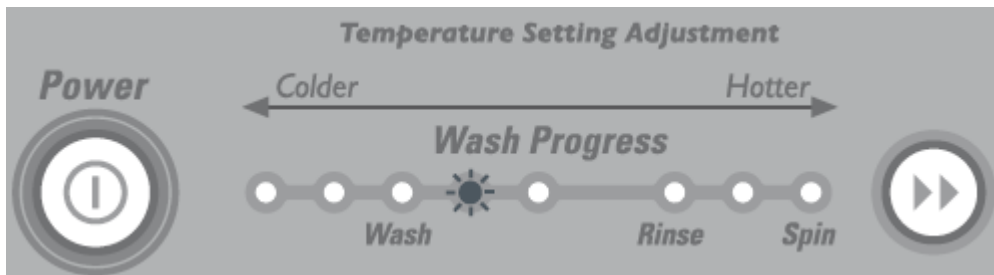

3.4.3 Controlled Cold (WashSmart, WA Only)

If the cold water inlet temperature is very low (below 20°C), an effective wash will not be obtained. The controlled cold option solves this problem by adding a small amount of hot water to raise the temperature of the wash. We have called this 'Controlled Cold'.

1. Turn machine on at the wall but do not press **POWER**.
2. Press and hold down the **START/PAUSE** button, then press **POWER**. Two quick beeps will be heard and the machine will show an unusual pattern of lights. In this mode the lights are used to indicate the different options available.
3. Use the **Wash Temp** buttons to select the **COLD** wash temperature.
4. The Wash Progress lights show the temperature adjustment possible. When the first progress light is on, the machine will fill with cold tap water only. Press **ADVANCE** to select the second light and the SmartDrive® will control the temperature to approximately 20°C. Each following light equals approximately a 1°C temperature rise.

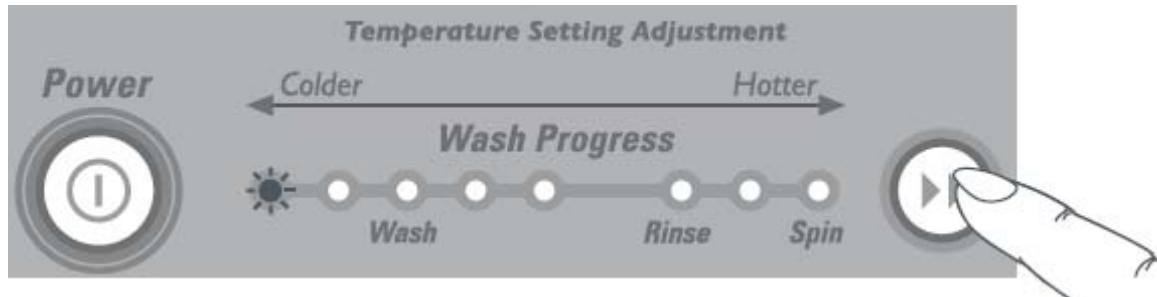

3.4.4 Wash Temperature Adjustment (FabricSmart, IW Only)

1. Turn machine on at the wall and touch the **POWER** button.
2. Touch the **Lifestyles/Options** button noting that **OPTIONS** is highlight, and then use the **Scroll** arrows ◀ or ▶ to highlight **Temperature**. Touch the **Select** ✓ button to enter.
3. Highlight the temperature required using the **Scroll** arrows ◀ or ▶ then confirm with the **select** ✓ button to set the temperature.
4. If the temperature is to be permanently programmed, when the "Save for Future Washes" screen appears, confirm **YES** with the **Select** ✓.



TEMPERATURE

Cold	Cold+	Warm/Cold
Warm	Warm/Hot	Hot

SAVE FOR FUTURE WASHES?

Yes	No
-----	----

3.5 Water Valves

The machine uses a dual valve block assembly. Independent coils control the hot and cold water supply, which feeds the water through a common outlet.

The WashSmart, FabricSmart, GW, WA & IW valve block has a location feature for the thermistor. There is no thermistor location feature on the QuickSmart, MW Washer.

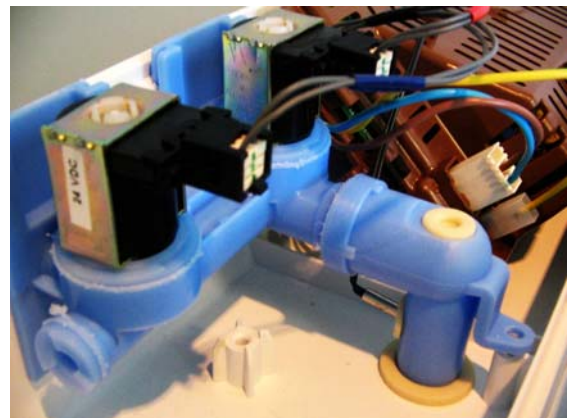

3.6 Diverter Valve (FabricSmart, IW Only)

The Diverter Valve is situated at the bottom of the outer bowl beside the Pump. It consists of a wax solenoid which heats up and moves a flapper to close off the drain enabling the water to be diverted back into the inner bowl, with the pump running. When powered on there is 160 volts DC across the terminals.

NB: The Valve takes approximately 1 minute to activate and 3 minutes to cool down and return to its normal position.

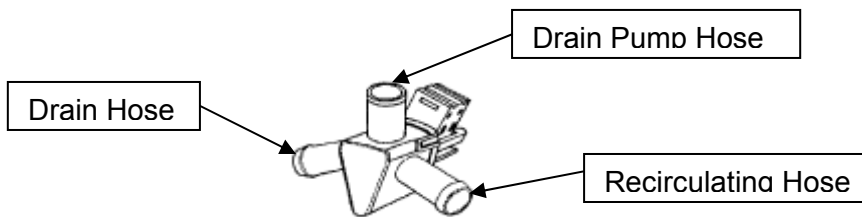

3.7 Water Level Measurement

The machine is fitted with a pressure sensor, which can control the fill to any water level. The pressure sensor is incorporated within the Motor Control Module and cannot be removed. The pressure tube connects from the Motor Control Module to the air bell at the bottom of the outer bowl, and is part of the harness assembly. Care must be taken when removing or refitting the pressure tube to the pressure sensor as too much force can damage this device.

3.7.1 Manual Water Level (QuickSmart & WashSmart, MW, GW & WA)

The agitator has 5 levels marked on its stem that can be used to help the user select the correct water level. Select the correct water level by using the mark nearest to the top of the clothes.

The levels marked on the agitator are a guide for the clothes and do not correspond exactly to the water level.

Occasionally water may be added during agitation. This is to maintain the water level due to the release of air trapped in the garments.

For example: If the garments sat between the medium and high marks on the agitator, choosing a medium water level would be better than choosing a high water level. Alternatively additional garments could be added so that the garments were brought closer to the high mark.

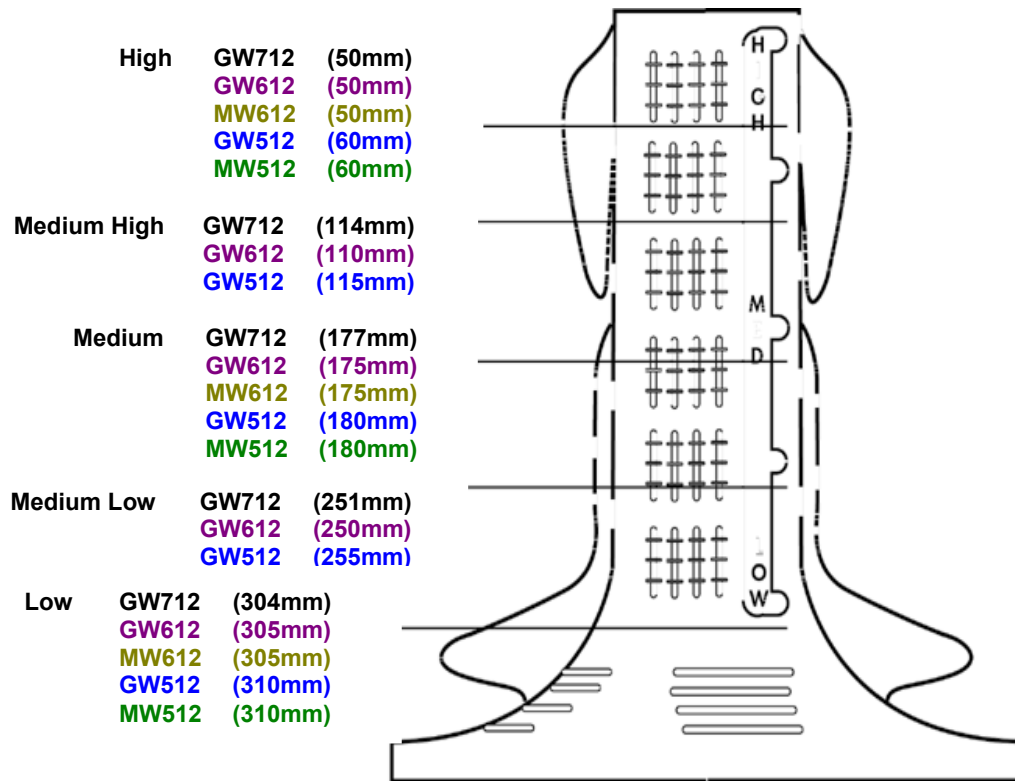

Water Level Settings

Tolerance for each water level = +/- 15mm

3.7.2 Auto Water Level (WashSmart, GW, WA Models)

The machine automatically selects the appropriate water level for the load when AUTO Water Level is selected, and will choose one of the pre-existing 5 water levels (low, medium low, medium, medium high and high). During fill the machine pauses occasionally to sense the water level. The machine checks if the water level is correct by using a series of 2 different agitate strokes. A slow stroke to sense the load and an agitate stroke to mix the load. If the machine detects that the water level is too low it will fill with more water and check the level again.

- When washing an unusual load, e.g. large bulky garments, pillows, it is recommended that the water level is manually selected.
- Manually select the water level if there is already water in the bowl.

If the machine does not fill to the correct level, the auto water level can be adjusted in the Option Adjustment Mode. Refer to the Use & Care manual for the various options adjustments available.

To enter the option adjustment mode:

1. Plug the machine in but do not press the POWER.
2. Press and hold the **Start / Pause** button, then press **Power**
3. Three quick beeps will be heard and the machine will show an unusual pattern of lights.
4. Carry out any option adjustments necessary.
5. Press the **POWER** button to return to the normal mode.

3.8 Motor

3.8.1 Stator

The stator used is **not interchangeable** with any previous phase or series of machine. This stator has 36 poles with the windings being Aluminium and is Identified by the printed marking **AL 60 190T** it looks the same as a copper Stator but is 19.5Ω per winding.

Stator (36 Poles)



Curved pole tips



Testing the Stator

If the stator needs to be tested we would first recommend testing the resistance of the windings at the harness that is connected to the Motor Control Module. (Refer to Section 5.9).

Note: Ensure that the Rotor and bowl are stationary when measurements are made.

Testing the stator from the console

The resistance of each individual winding is approximately 19.5Ω , however when testing the stator from the console we are testing across two windings therefore the resistance should be approximately $39\Omega \pm 10\%$

To test all windings you will need to measure across:

- Red & Blue
- Red & Yellow
- Blue & Yellow

If the meter shows an incorrect reading we would then recommend testing the stator from underneath the machine as there could be a fault in the wiring harness. To test the stator, remove the rotor and stator. Refer to Sections 8.19 and 8.20.

Note: Two clamp plates are used to secure the Stator, one on each side. The four bolts are tightened to a torque of $5-7Nm$. The plastic bolt for securing the Rotor requires a 16mm socket and should be tightened to $8-10Nm$.

Testing the Stator

After removing the Stator, it can now be tested.

Test points are:

R (Red) / B (Blue)

B (Blue) / Y (Yellow)

Y (Yellow) / R (Red)

The value should be approx. 39Ω +/- 10% across any of the two windings.

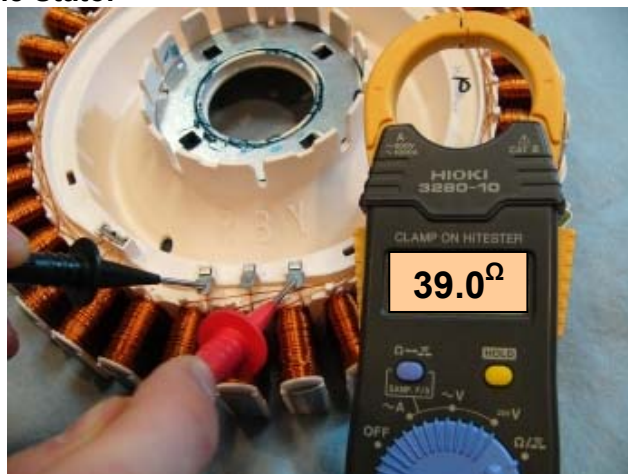

3.8.2 Rotor

The rotor is also unique to this machine. It has 48 blocks of individual magnets in a black moulding.

The rotor is not interchangeable with any previous phase or series of machine.

The rotor can physically be interchanged, however electrically they are **incompatible**.

The photograph below shows the Rotor used.

Black



3.9 Pumps

Blocked Pump Detection

This is achieved by monitoring the water level during drain. If the water level has not dropped by approximately 3mm within a predetermined time period (approximately 9-10 minutes), then the product will report a pump fault.

3.9.1 Selni

The pump is coupled directly to the outer bowl. This eliminates tub to pump hoses and the accompanying seals, clamps etc. The pump housing is an integral part of the outer tub.

When removing the pump up to a litre of water may leak from the pump cavity. When refitting the pump; lubricate the seal face with liquid soap or detergent (do not use grease).

Note: The Resistance of the pump should read 33Ω +/- 8%. (Refer to section 2.6)



3.9.2 Hanning

This pump is an asynchronous pump that will start randomly in either direction.

The pump comes with its own bracket which is mounted to the outer bowl by three screws. This configuration requires a tub to pump hose in the form of an elbow and accompanying hose clips

When removing the pump up to a litre of water may leak from the pump cavity.



Note: The Resistance of the pump should read 93Ω +/- 8%. (Refer to section 2.6)

3.10 Lid Lock

All washers use a lid lock to secure the lid closed, which is locked during the spin and drain out part of the cycle, prior to spray rinse the lid will lock down until the completion of the spin.

When locked on the QuickSmart, WashSmart, MW, GW & WA machines the "Lid Locked" LED will illuminate. Once the spin has completed, the lock will release and the lid can be opened. To open the lid during the cycle, while the LED is illuminated press the **START/PAUSE** button, the machine will come to a halt, and the lid locked LED will extinguish. If the lid is left open, the machine will be unable to lock the lid and the cycle will be halted. The machine will play a tune and the lid lock will flash until the lid is closed and the **START/PAUSE** button is pressed.

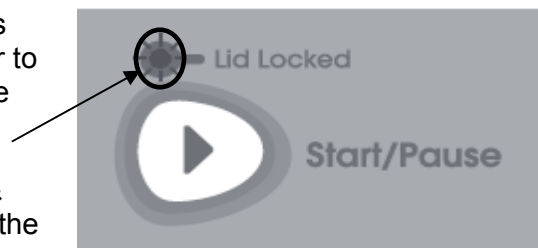

QuickSmart, WashSmart, GW, WA & MW

When the lid lock is activated on the FabricSmart, IW machine the LCD screen will display a symbol of a padlock. If the lid is left open, the machine will be unable to lock the lid and the cycle will be halted. The machine will play a tune with the words **“Please Close The Lid”** being displayed on the LCD screen.

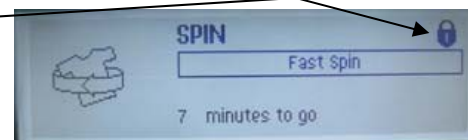

FabricSmart, IW

- If the lid-lock fails in the closed position, the locked lid can be forced upwards and out of the lock. **Note: This is the only time in which we would recommend doing this as this action will DAMAGE the lid lock which will need replacing and the lid tang will need to be inspected for damage.**
- If the lid lock harness is damaged, the complete lid lock assembly will need to be replaced.

If the power supply is cut during the spin cycle, the machine will keep the lid locked until the rotor has ceased to turn (3 to 10 secs). Only then will it release the lock. The motor is acting like a generator and allows the lock to stay energized under the bowls inertia.

In a brown out situation, the machine will restart at the beginning of the section of the cycle it was on and continue the wash. The lid lock would then be reactivated.

3.11 Inner Bowl and Outer Bowl

The outer bowl is the assembly to which all the motor, pump system, suspension rods, etc are mounted. Within the outer bowl is the inner bowl and the agitator. During spin, the agitator and inner bowl have to be coupled together and turn as a single unit. In agitate; the agitator and inner bowl are free to rotate independently.

The inner bowl is free to move in a vertical direction. The position of the inner bowl is determined by the water level. At the base of the inner bowl is a flotation chamber consisting of a number of individual cells. When the machine is filling with water, the pressure on the air in these cells increases as the water level rises until eventually the inner bowl floats upwards and disengages the driven spline from the drive spline. This action frees the agitator from the inner bowl and allows it to move freely in both directions.

When the water is draining, the pressure on the air trapped in the cells of the flotation chamber decreases allowing the inner bowl to settle back down onto the drive spline and re-engage the driven spline, thus allowing the agitator and inner bowl to turn as one unit. The floating bowl is also used to detect if the user has selected the correct water level for the size of the wash load.

The point at which the bowl starts to float is determined by the water level and the size of the load. The greater the load, the more water is needed before the inner bowl will float. By detecting the point at which the bowl floats, the machine can determine whether the correct water level for the particular wash load has been chosen by the operator. If the operator has chosen a level that is too low for the load, the machine will override that choice and fill to the correct level. This is to ensure optimum wash performance and minimal clothes wear. If the user has selected a level that is higher than necessary, the machine will still fill to the users selected level.

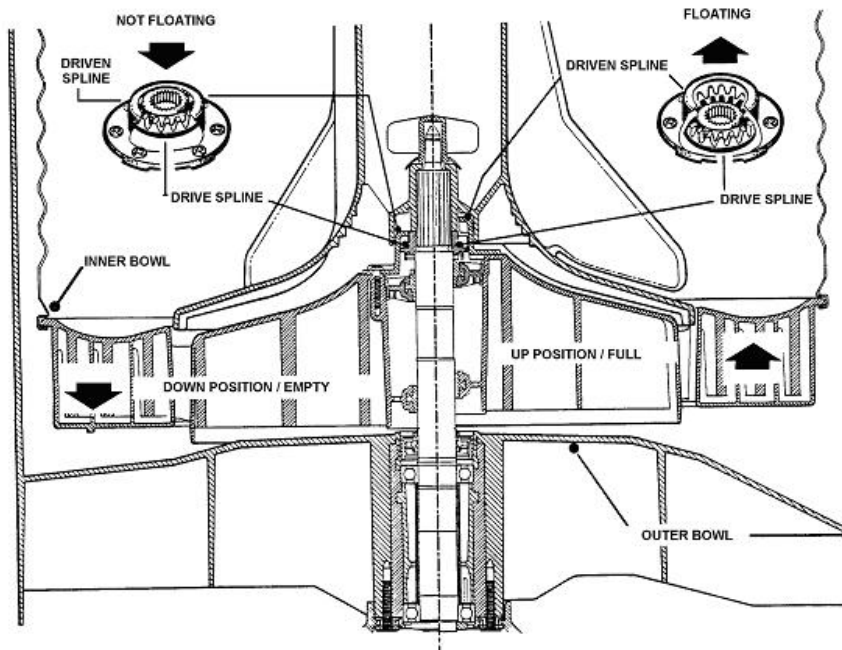

3.11.1 Detection of Inner Bowl Float off Point – Bowl Check

During fill the inner bowl will rotate to ensure that the clothes are evenly saturated with water. When the chosen water level is reached, and before the agitate cycle is started, the machine will carry out inner bowl float checks (bowl check). The inner bowl will stop and commence a number of small agitate type actions. During this action the machine determines if the inner bowl has floated. If it has the machine will determine the required water level and check if the operator has selected the correct level. If the inner bowl has not floated, the machine will continue filling and check again later. The water level at which the inner bowl floats is not necessarily the same as the final water level.

3.11.2 Detection of Inner Bowl Re-Engagement – Bowl Engage Check

After the water has drained, the inner bowl will sink down and re-engage onto the drive spline. To ensure the inner bowl has re-engaged correctly, the machine will carry out a bowl re-engage test sequence (bowl check). Bowl check consists of a series of short agitate type actions before the spin cycle starts. A sound may be heard as the inner bowl re-engages.

3.11.3 Balance Rings

The inner bowl has 2 balance rings, one at the top, and one at the bottom. These are sealed compartments half full of water. This water allows the bowl to balance. If one or both of these rings have lost water then the machine will have out of balance issues and the inner bowl must be replaced. The easiest way to determine a loss of water is to weigh the bowl on an accurate set of scales.

Inner Bowl Weights

Compact	7.30kg +/- 225g
Medium	8.37kg +/- 225g
Large	10.48kg +/- 275g

3.12 Agitator

The agitator design differs from conventional designs in that it is made of very flexible plastic that bends and flexes as the clothes are moved around the bowl. The agitator action is similar to that of a fish moving through the water, so the side-wards motion is translated to forward thrust. This is not only more forgiving on the clothes but helps to slowly move the clothes around the bowl in a toroidal motion, i.e. a vertical circular motion. The fins at the top of the agitator pull the clothes on

the surface of the water inwards and then push them downwards. The bottom fins then push the clothes towards the outside of the bowl again and back up to the surface.

The agitator also features guides on the side to help the user choose the correct water level for each load size. The guides relate to the level that the dry clothes come up to, which relates back to the correct water level. The agitator also gives the user information when measuring detergent, to ensure that they dose correctly for the load size.

3.13 Lint Removal System

The machines self cleaning lint removal system works by continuous water circulation, resulting in the separation of lint from the wash water. As the agitator moves, the specially designed vanes on the bottom create turbulence. The agitator acts as a centrifugal pump, circulating the wash water.

As a result of the agitator action, lint and wash water are sucked into the agitator stem and down to the base where they are directed into the cavity between the inner bowl and outer bowl. The extruded holes of the inner bowl are shaped to allow the wash water to flow back into the bowl, but prevent the lint from following. The lint then floats to the surface of the water between the inner and outer bowl and remains there until it is flushed out the drain at the end of the wash cycle.

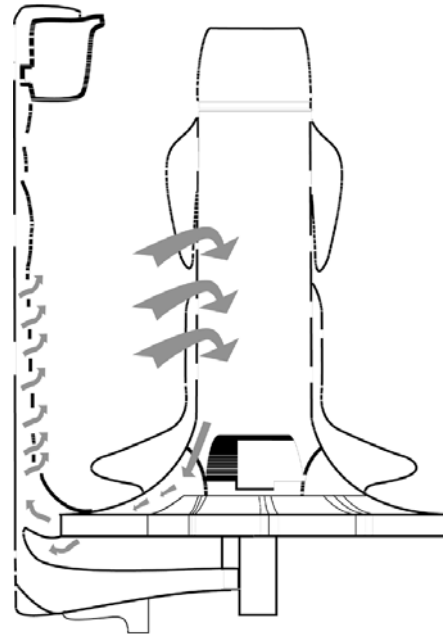

Automatic Lint Removal System

3.14 Fabric Softener Dispensing

TYPE: It is recommended that softener sheets should be used in the dryer rather than using liquid softener in the washing machine. Liquid softener has been known to produce a waxy build-up inside washing machines, called Scrud. We do however; provide a fabric softener dispenser for those who prefer liquids. It is recommended thinner varieties be used over thicker ones as they dispense more cleanly.

WHERE: The liquid fabric softener goes in the dispenser cup on top of the agitator. The fabric softener is automatically dispensed into the final deep rinse. In this way the fabric softener and detergent are separated, as they are not compatible.



Pour fabric softener into the dispenser as shown

The dispensing stages

1. Fabric softener remains in the dispenser cup during the fill, agitate and drain phase of the wash program.
2. During the first phase of the spray rinse it is centrifuged out of the cup into the body of the dispenser.
3. The fabric softener is held hard up against the sides of the dispenser body by centrifugal force throughout the spray rinse.
4. At the end of spray rinse the softener drains out of the dispenser, down the centre of the agitator where it is dissolved in the incoming deep rinse water.

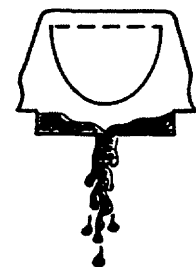
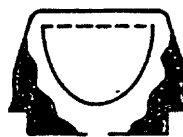
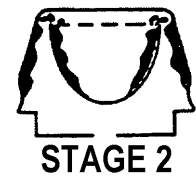
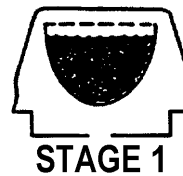

STAGE 3

STAGE 4

3.14.1 Scrud

If fabric softener is used regularly it will eventually cause a build up within the outer bowl. This can result in black flakes present in the wash load that can stain garments. To remove scrud follow the procedure below.

Step 1: Add a full cup of a good quality dishwashing powder in to the machine.

Step 2: Set the machine to a Heavy Duty cycle, select a Hot Wash temperature, High Water level and allow the machine to agitate for 10 minutes.

Step 3: Leaving the lid closed, turn the machine off and allow soaking overnight.

Step 4: The following day, turn the machine on and advance to the spin cycle to drain the water from the machine. After the water has drained, turn the machine off then back on again, and select a Heavy Duty cycle, Hot wash, High Water level, and allow the machine to complete a full cycle to ensure that all of the loose scrud and residual detergent has been flushed away.

Note: If there is an extremely heavy build up the above procedure may have to be repeated. If scrud residue is still present the removal of the inner bowl and cleaning manually may be needed.

4 SIZE SETTING MODE

It is important to set the size switch setting into the Motor Controller's memory whenever a replacement Motor Controller and or FabricSmart, IW Display Module is fitted to the machine. Failure to do this will result in the machine faulting with fault code 9. The size setting of the SmartDrive may be checked in the size setting mode.

4.1 QuickSmart, WashSmart, MW, GW & WA Size setting

Accessing size setting mode is the best way to check the set size of the machine.





To set the size switch, turn the power on at the supply point and off at the console. Press and hold the **WASH TEMPERATURE UP** button then press the **POWER** button. The washer will give 4 short beeps and the pattern of LEDs will change.

One of the following buttons needs to be pushed to lock the size into memory.

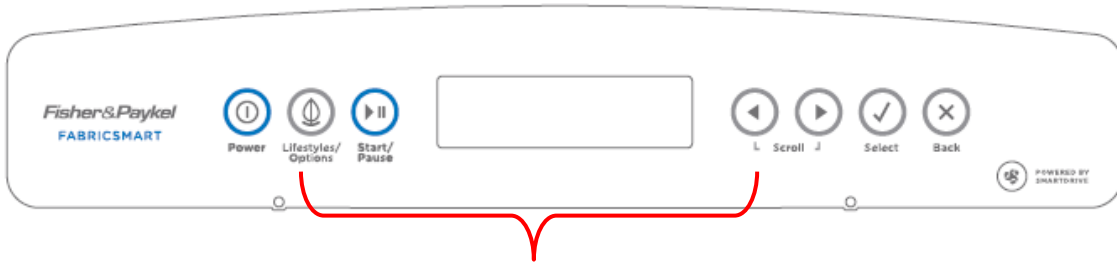
- Press **WASH TEMP UP** button, the **COLD** LED is on for **5.5kg** (560mm wide).
- Press **WATER LEVEL UP** button, the **LOW WATER** LED is on for **6.5kg / 7.0kg** (600mm wide).
- Press **SPIN SPEED UP** button, the **SPIN HOLD** LED is on for **7.5 / 8.0kg** (650mm wide).
- Press **POWER** to confirm the setting and also exit this mode.

4.2 FabricSmart IW Size setting



To set the size, turn the mains on at the supply point and off at the console. Press and hold the **Lifestyles/Options**  and the **Left Arrow**  button until the size setting screen is displayed. This will present the option of Medium or Large in the LCD screen. Highlight the correct size using either **Scroll** arrows  or  then power off the display with the **Power** button, your selection is automatically saved.



If the size setting is wrong, the machine will have the following settings incorrect: -

- The Auto Water Levels chosen may be incorrect.
- The High Water Level may be incorrect by as much as 40mm.
- The wash profiles may be incorrect resulting in poor wash performance or vigorous wash actions causing tangling, splash over or excess linting.
- Water saver settings.

5 DIAGNOSTIC MODE

To enter diagnostic mode, for each of the different models follow the steps below.

5.1 QuickSmart, WashSmart, MW, GW and WA Models

1. Turn the power on at the power point but off at the machine.
2. Press and hold the **WASH TEMPERATURE DOWN** button and then press the **POWER** button until the machine gives 2 short beeps and lights up.
3. Release the buttons after the beeps as the beeps indicate diagnostic mode has been entered.

5.1.1 Last Fault Data

When in diagnostic mode the last fault can be found by pressing the **SPIN SPEED UP** or **DOWN** buttons until the **HOLD** and **SLOW** lights are illuminated. Binary can then be read from the wash progress lights.

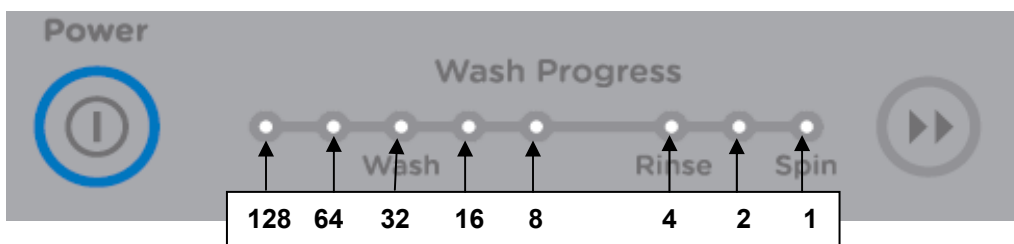

5.1.2 Drain Pump Test

When in diagnostic mode to activate the drain-pump press the **REGULAR** button. To deactivate the pump, press **REGULAR** button again.

5.1.3 Water Valve Test

The water valves can be activated in diagnostic mode by pushing **WASH TEMPERATURE UP** button to activate the **Hot Valve** and **WASH TEMPERATURE DOWN** button to activate the **Cold valve**.

Pressing each button once will activate the valve. To de-activate the valve press the same button again. This is also good to use when installing machines as it takes the shock out of the fittings and seals and allows checking for leaks on the inlet hoses, at both machine and tap ends.

Caution: Do not leave the machine unattended when either or both valves are operating.

5.1.4 Restart Feature

If a fault occurs in the machine, the diagnostic system will detect it. However, instead of displaying a fault code immediately, the machine will try to restart. If the fault was only of temporary nature, the machine will restart and finish the cycle. If there is a continuous fault the machine will try to restart a number of times.

This process could take up to 8 minutes depending on the type of fault. After this, if the machine still cannot restart, the fault code is displayed and the machine will beep continuously. The number of retries will depend on the fault that it has detected, however the maximum number of retries for any one fault is 32 times.

The restart feature is defaulted to "ON" when a machine leaves the factory. For servicing we strongly recommend that this feature be disabled.

To disable the restart feature follow the procedures below:

1. Enter diagnostic mode (Refer to Section 5.1.)
2. Press the **WATER LEVEL DOWN** button so that the low water level LED is not lit.
3. Press the **POWER** button to turn the display off (the 5 leftmost wash progress LEDs will be flashing).
4. Press the **POWER** button to turn the machine on.
5. The machine can now be tested on any cycle.

To turn the restart feature on, either repeat the steps above or switch off the mains supply to the machine.

The restart feature can be permanently programmed in to the machine's memory. When in diagnostic mode press and hold the **ADVANCE** button down at the same time pressing the **WATER LEVEL DOWN** button. A long beep will acknowledge the setting has been retained in EEPROM. Press the **POWER** button to retain selection as with size setting. To remove from the permanent memory, repeat the above procedure.

Note: This feature is designed as a service aid only and should be left on in the customer's home. To return to normal operation, and to reset the restart feature to the factory setting, switch the machine off at the wall or disconnect from the mains supply.

5.1.5 Recycle Feature

The recycle feature, when enabled, will cause the machine to continuously repeat the cycle that has been selected. At the completion of the spin cycle the machine will power off briefly then power back up again and will start the wash cycle programmed.

This feature is useful to help identify an intermittent problem, and would be best used if the machine had been taken back to a workshop for service.

To turn the recycle feature on follow the procedures below:

1. Enter diagnostic mode (Refer to Section 5.1).

421827

2. Press the **WATER LEVEL UP** button so that the Medium water level LED is lit.
3. Press the **POWER** button to turn the display off (the 3 rightmost wash progress LEDs will be flashing).
4. Press the **POWER** button to turn the machine on.

The machine can now be tested on any cycle.

Note: This feature is designed as a service aid only and should be OFF in the customer's home. To return to normal operation, and to return the recycle feature to the factory setting, switch the machine off at the wall or disconnect from the mains supply.

5.1.6 Hot Bowl Flag

If the machine has been filled with hot water and has not had a cold rinse, it will not spin up to its full speed of 1000 RPM. Its maximum speed will be restricted to a maximum of 700 RPM. This is to prevent distortion of any internal plastic components that may occur at a high spin speed.

To check to see if this flag has been enacted, firstly enter diagnostic mode (Refer to Section 5.1). The LED adjacent to **QUICK WASH** on the WashSmart, GW & WA machines and the **ECO ON** for the QuickSmart machine will be lit.



To clear this flag and allow the machine to spin to 1000RPM, either press the **OPTIONS** or **ECO** button while in diagnostic mode turning the LED off, or put the machine through a complete final rinse.

5.1.7 Data Download

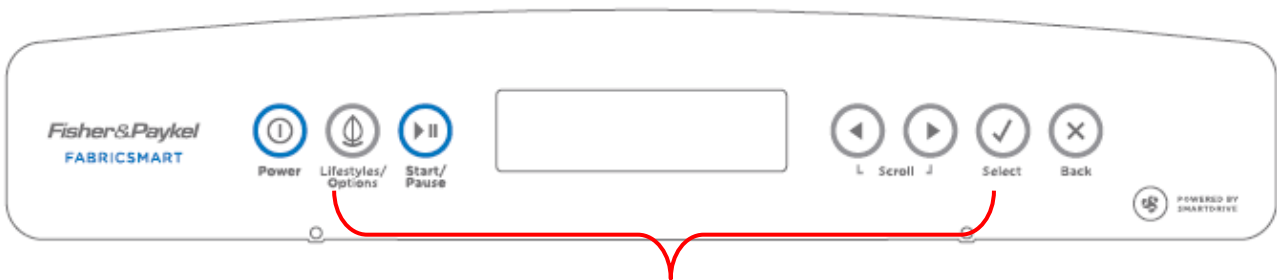

Enter diagnostic mode. Press **START/PAUSE**. The Lid Lock LED will now be on and flickering. Place the download pen over this LED and follow the instructions supplied with the data download program.

5.2 FabricSmart, IW (intuitive)

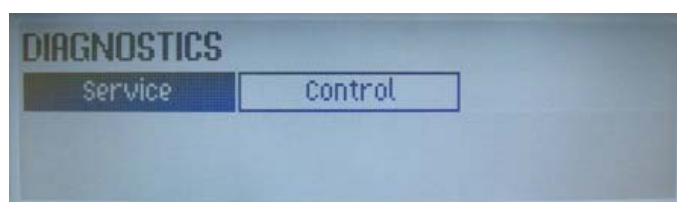

To enter the **DIAGNOSTIC** mode, ensure the mains is on at the supply point. Press and hold the **Lifestyles/Options**  and **Select**  buttons. Keep the buttons pressed for at least 2 seconds, after which time two beeps will sound and the screen below will appear.



Use either **Scroll** arrows  or  to highlight the screen you wish to view, then touch the **Select**  button to enter the appropriate screen.

5.2.1 Service Screen

Upon entering the service screen, one of the following will appear in the LCD display.

- Warning Status / Fault Status
- Machine Status

To scroll between these use either scroll arrow ◀or▶.

5.2.2 Warning Status / Fault Status Screen

WARNING STATUS	FAULT STATUS
Warning code: 8	Fault code: 45
Cycles ago: 0	Cycles ago: 0
At progress: Spin	At progress: Wash 4

Warning Status

This screen displays the last USER WARNING FAULT that occurred and will show how many cycles ago and in what part of the cycle it occurred.

The User Warning Faults are as follows:

1. No Taps
2. Overloaded
3. Out Of Balance
4. Over Suds or water still in the machine during spin
5. No Hot Water
6. No Cold Water
7. Agitate Overloaded
8. Lid Lock

Fault Status

This screen displays a fault code for the last fault that has occurred and will show how many cycles ago and in what part of the cycle it occurred.

The fault code number can now be checked in the detailed fault codes, to ascertain what repairs may be necessary.

For fault code details (refer to section 7).

5.2.3 Machine Status Screen



In the top half of the screen it displays the following information.

Size is the size of machine, (650mm = Large)

HVDC is for on line testing in the factory.

WL displays the water level in mm.

Temp is the actual temp of the water entering the bowl.

The lower half of the screen displays the status of the following components.

- Hot Valve
- Cold Valve
- Pump
- Diverter Valve

Component Testing

This screen enables the components that are displayed to be tested.

- To test a component, firstly highlight the component by using either scroll arrow ◀ or ▶.
- Activate the component by touching the **Select** ✓ button.
- Deactivate the component, by touching the **Select** ✓ button again.

Note: *Diverter Valve when activated will display the word heating then change to on and when deactivate will display the word cooling then when cooled will change to off.*

5.2.4 Diverter Valve Test

The recirculation valve can be activated while in diagnostics, machine status mode, by highlighting with the **Scroll** arrows ◀ or ▶ the **DIVERTER** option and turning it on with the **Select** ✓ button. The displayed state will change from “Off” to “Heating.” Then by highlighting with the **Scroll** arrows ◀ or ▶ the **COLD** option and turning the cold water valve “On” with the **Select** ✓ button, fill the Bowl with water so the Water Level indicator on the LCD reads 100mm,. Once the water level reads 100mm turn off the cold water valve. Activate the pump by highlighting with the **Scroll** arrows ◀ or ▶ the **PUMP** option and turning it on with the **Select** ✓ button; the water should be circulating from the rear right hand corner of the inner bowl. To turn the recirculation valve “Off” **Scroll** with the arrows ◀ or ▶ and highlight the **DIVERTER** option turning it off with the **Select** ✓ button, the displayed state will change from “On” to “Cooling”, when cooled down it will change to “Off”. The diverter valve will take up to 3 minutes to cool and close before allowing the water to drain. Once the water has drained turn off the pump.

5.2.5

5.3 Control Screen

Upon entering the control screen, the following will appear in the LCD display.

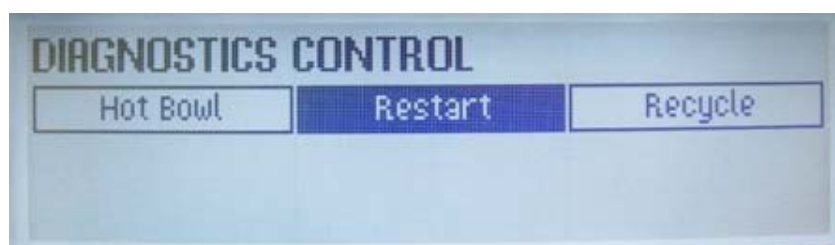

5.3.1 Hot Bowl Flag

If the machine has been filled utilising the hot water valve (i.e. warm or hot fill) and has not had a cold rinse, the electronics will not allow the machine to spin up to its full speed of 1000 RPM. It will only allow the spin speed to reach 700 RPM.

To remove this flag, enter the Control Screen mode, ensure the **HOT BOWL** option is highlighted, and then touch **Lifestyles/Options** Ⓛ button. Alternatively this flag can also be removed by putting the machine through a complete final rinse.

5.3.2 Restart Feature

The FabricSmart™ IW leaves the factory with the **RESTART** set to ON, this is indicated in the screen by the word **RESTART** highlighted. To turn the **RESTART** feature OFF, touch the Left scroll arrow ◀. This will remove the highlight from the word **RESTART**.

When servicing the machine, it is more convenient to turn the RESTART feature OFF. This will allow any fault in the system to show up immediately it occurs.

With the RESTART feature on: (Factory Default setting)

1. If a fault occurs in the machine, the diagnostic system will detect it. However, instead of displaying a fault code immediately, the machine will try to RESTART.
2. If the fault was only of temporary nature, the machine will restart and finish the cycle.
3. If there is a continuous fault the machine will try to RESTART a number of times. This process could take up to 8 minutes depending on the type of fault. After this, if the machine still cannot restart, the fault code is displayed and the machine will beep continuously. The number of retries will depend on the fault that it has detected, however the maximum number of retries for any one fault is 32 times.

NOTE - This feature is designed as a service aid only and should be left ON in the customer's home. To return to normal operation, and to reset the RESTART feature to the factory setting, switch the machine off at the wall or disconnect from the mains supply.

421827

To identify that the RESTART feature has been activated, refer to the Restart / Recycle table. (Refer to Section 5.3.4)

5.3.3 Recycle Feature

At the end of servicing, the machine may require an extended test where the machine can be left to complete a number of wash cycles. By turning on the **RECYCLE** feature, the machine will continuously repeat the wash cycle until the **RECYCLE** feature is turned off. To toggle this feature on or off, touch the right scroll arrow . When the recycle feature is on, the word **RECYCLE** will be highlighted.

NOTE - This feature is designed as a service aid only and should be OFF in the customer's home. To return to normal operation, and to return the recycle feature to the factory setting, switch the machine off at the wall or disconnect from the mains supply.

To identify that the RECYCLE feature has been activated, refer to the Restart / Recycle table. (Refer to Section 5.3.4)

5.3.4 Restart / Recycle Table LCD

As the FabricSmart™ IW has only one LED (located above the Lifestyles/Options  button) the state of the LED will signify which feature has been selected or not selected. The table below explains the state of the LED when the machine is on at the wall and off at the machine.

LED: Off (Factory Default)	Restart on
	Recycle off
LED: Solid	Restart off
	Recycle on
LED: Slow Flashing	Restart off
	Recycle off
LED: Quick Flashing	Restart on
	Recycle on







5.3.5 Restart / Recycle Features Permanently Programmed

It is possible for the Restart Feature to be disabled, or the Recycle Feature to be enabled, or a combination of both to be permanently programmed into the memory of the electronics so that in the event of a power cut the electronics will remember the setting.



The factory settings are:

- Restart is enabled
- Recycle is disabled

If a machine is encountered with the Restart/Recycle features not set to the factory defaults, the machine must be re-programmed using following steps;

1. Enter diagnostic mode by pressing and holding the **Lifestyles/Options**  and **Select**  buttons. Keep the buttons pressed for at least 2 seconds, after which time two beeps will be heard and a screen showing 'Service' & 'Control' will appear.
2. Using either scroll arrows  or , highlight the 'Control' screen and then touch the **Select**  button.
3. To enable/disable the Restart feature permanently, press and hold the **Left Scroll Arrow**  for three seconds until a beep is heard.
4. To enable/disable the Recycle feature permanently, press and hold the **Right Scroll Arrow**  for three seconds until a beep is heard.

5.4 Data Download

To activate the data download, enter the diagnostic mode with the power on at the supply point press and hold the **Lifestyles/Options**  and **Select**  buttons. Keep the buttons pressed for at least 2 seconds, after which time two beeps will sound. Then press the **Start/Pause**  button. The LED above the Lifestyles button will be on and flickering.

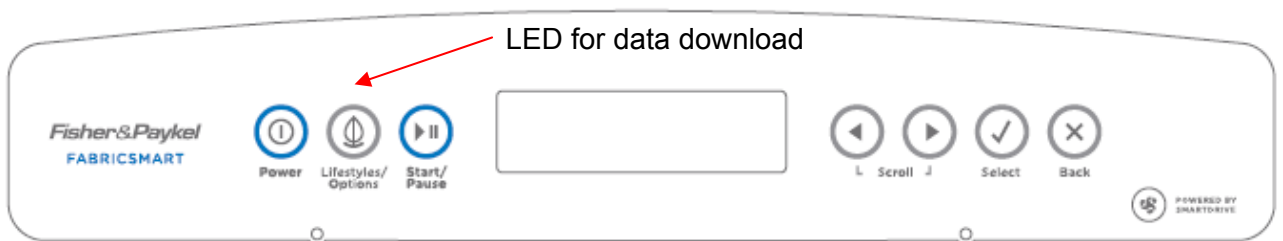

Place the download pen over this LED and follow the instructions supplied with the data download program.

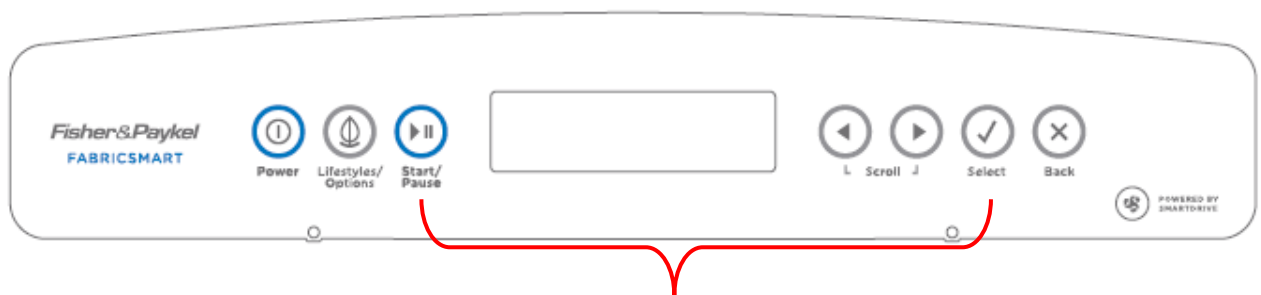

5.5 Showroom Mode



Press and Hold **START/PAUSE** , then press the **SELECT**  button

Showroom mode will play the introduction and repeat it continuously, until the machine has been isolated from the power supply.

To access the showroom mode follow the steps below.

1. Turn the power supply to the washing machine on.
2. During the introduction sequence on the LCD display (which lasts for approximately 1 minute) press and hold the **START/PAUSE**  button and the **SELECT**  button, and hold these buttons for at least two seconds.



To exit, turn off the power supply to the washing machine at the wall.

5.5.1 Settings Adjustment Mode

To access the settings menu

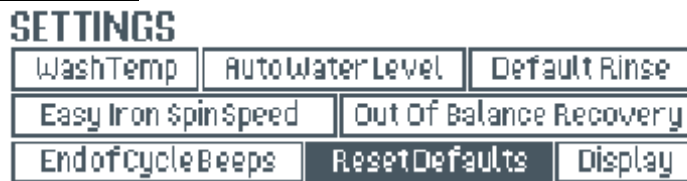
- Touch the **Lifestyles/Options**  button, **OPTIONS** will be highlighted, **Scroll** with the arrows  or  highlighting **SETTINGS** and select . The SETTINGS menu will then be displayed.



- Scroll and select the option you wish to adjust.
- Scroll and highlight your preferred setting and then touch the select  button. This option will be permanently set.
To unset the option, repeat the above steps.
- To exit and save the SETTINGS, touch the back  button.

The options that can be adjusted are:

- Wash Temperature. Each increment is approximately 2°C.
- Auto Water Level. This increases or decreases the fill level that auto will detect.
- Default Rinse. The default rinse can be set to either; spray and deep, single deep, double deep or shower.
- Easy Iron Spin Speed. The spin speed for the Easy Iron cycle can be set at either slow (330rpm) or medium (670rpm).
- Out of Balance Recovery. The out of balance recovery action can be set to be either automatic, where the machine will fill with water and agitate to redistribute the load, or it can be turned off, where the machine will stop and beep.
- End of Cycle Beeps. These can be set to zero, five or fifteen.
- Reset Defaults. Will cancel any of the adjustments made and reset all settings to the factory defaults.
- Display. Enables the adjustment of the brightness & contrast of the LCD display.

5.6 User Warnings QuickSmart WashSmart MW, GW & WA

There are a number of warnings, which are generally caused by the user or poor installation. These warnings should be able to be corrected by the user. The machine signals user warnings by flashing LEDs and a rippling set of 5 beeps repeated every 6 seconds. This is the same tone that is heard when the machine is first plugged into the mains power.

Most of this information is available to the user in the Use and Care manual.

5.6.1 Hot Water Temperature LED Flashing (Insufficient Hot Water)

Possible causes:

1. Check that the hot water is connected and that the tap is turned on.
2. Check that the water temperature is not too low. The water temperature may need to be 60°C for a hot wash.
3. Check that the hot water inlet hose is not connected to the cold water supply.
4. Check that there are no kinks in the inlet hoses.
5. Check that the filter on the hot inlet hose at the tap end is not blocked.
6. Check that the filter screen in the hot inlet valve is not blocked.
7. Check the resistance of the thermistor. Resistance is 10kΩ @ 25 °C. Replace if well outside of this range.
8. Check the size is set correctly.

Note: If the machine is set to controlled cold, hot water may be required to achieve 20 °C.

5.6.2 Cold Water Temperature LED Flashing (Insufficient Cold Water)

Possible causes:

1. Check that the cold water is connected and that the tap is turned on.
2. Check that the flow rate is not too low. The product requires a minimum flow rate of 3 litres per minute.
3. Check that the cold water inlet hose is not connected to the hot water supply.
4. Check that there are no kinks in the inlet hoses.
5. Check that the filter on the cold inlet hose at the tap end is not blocked.
6. Check that the filter screen in the cold inlet valve is not blocked.
7. Check the resistance of the thermistor. Resistance is 10k Ω @ 25 °C. Replace if well outside of this range.
8. Check the size is set correctly.

5.6.3 Hot & Cold Water Temperature LED's Flashing (No Water)

Possible causes:

1. Check that water is connected and that the taps are turned on.
2. Check that there are no kinks in the inlet hoses.
3. Check that the filters on the inlet hoses at the tap end are not blocked.
4. Check that the filter screens in the inlet valves are not blocked.
5. Check that the flow rate is not too low. The product requires a minimum flow rate of 3 litres per minute.
6. Check that the drain hose is not too low or the drain hose is not pushed into the standpipe too far and the water is siphoning out of the machine.
7. Check the size is set correctly.

5.6.4 High Water Level LED Flashing (Overloaded Product)

Possible causes:

1. Check that the product is not overloaded.
2. Check the user has not selected the wrong water level.
3. Check that the inner bowl assembly is not jammed to the agitator with any foreign object that may be caught under the agitator skirt.
4. Check that the clutch teeth are not locked together with dirt, detergent or lint. Check that the teeth are not broken.

5.6.5 First Rinse or Final Spin and Current Spin Speed LED Flashing (Out of Balance)

Possible causes need to be checked in the following order

1. Even distribution of the load.
2. The machine is both level and stable on the floor.
3. That the feet have the rubber inserts fitted and the cabinet corners are clear of the floor.
4. That machine is correctly installed, is level and does not rock on the floor.
5. The bias spring is fitted between the top of the neck ring and the front left hand suspension rod.
6. The suspension is not catching or bouncy. If so, replace all four-suspension rods.
7. Both balance rings of the inner bowl contain water. The most accurate way is to check the weight of the inner bowl (Refer to Section 2.13).
8. That the holes on the inner bowl have been punched through or are not blocked.

5.6.6 First Rinse LED or the Final Spin LED is flashing (Suds)

This warning is generated if the machine senses too much drag on the inner bowl.

1. Too much detergent generally causes this. If so, dissolve the suds by flushing water through the machine and re-test.
2. Check that the pump is not partially blocked, or that the drain hose is not kinked.
3. Check that a garment or foreign object is not restricting the movement of the inner bowl.
4. Check that the main bearings are not tight.

421827

5.6.7 Lid Lock LED Flashing

This warning is generated if the electronics have detected that the lid has not been closed.

1. Check that the tang on the lid is not bent or broken.
2. If the lid is closed and the tang is ok, replace the lid-lock assembly.

5.6.8 Demonstration Mode (All LEDs flashing in patterns)

This feature is designed for in store demonstration purposes. So the machine can draw attention to itself with a selection of flashing LEDs. In this mode it cannot be started. To select demonstration mode press and hold the **Advance** button, then press the **Power** button.

During demonstration mode the LEDs will alternate between all on, LEDs flashing, and all LEDs off. To return to normal operation, the mains supply must be switched off.

5.7 Diagnostic Table QuickSmart, WashSmart, MW, GW & WA Models

To use this table, firstly enter Diagnostic Mode (Refer to Section 5.1). The different levels of information can be extracted by using the Spin Speed up and down buttons.

Diagnostic Level	Spin Speed LEDs				Diagnostic Info Displayed
	Fast	Med	Slow	Hold	
0	OFF	OFF	OFF	OFF	Last User Warning Number
1	OFF	OFF	OFF	ON	Last User Warning Cycle Position
2	OFF	OFF	ON	OFF	<i>Factory use only – Not applicable to the field</i>
3	OFF	OFF	ON	ON	Fault Code at last fault (if within the last 8 cycles)
4	OFF	ON	OFF	OFF	<i>Factory use only – Not applicable to the field</i>
5	OFF	ON	OFF	ON	Cycle count at last fault (low byte)
6	OFF	ON	ON	OFF	Cycle count at last fault (high byte)
7	OFF	ON	ON	ON	Cycle position at last fault
8	ON	OFF	OFF	OFF	Water Temp (deg C)
9	ON	OFF	OFF	ON	Cycle count (low byte)
10	ON	OFF	ON	OFF	Cycle count (high byte)
11	ON	OFF	ON	ON	Motor speed (RPM)
12	ON	ON	OFF	OFF	Water Level
13	ON	ON	OFF	ON	EEPROM version number
14	ON	ON	ON	OFF	Motor Controller software Version No.
15	ON	ON	ON	ON	Display Software Version No.

Diagnostic Mode 0, Last User Warning Number

The Last User Warning Number is displayed on the Wash Cycle LEDs in binary* form and can be calculated by totalling the binary* value of the Wash Cycle LEDs. Using the chart below to identify the last user warning.

Binary Count	User Warning
0	No warning
1	No taps
2	Overload
3	OOB
4	Suds
5	No Hot
6	No Cold
7	Agitate overloaded
8	Lid not Locked

Diagnostic Mode 1: Wash Cycle Position of Last User Warning Number

The Wash Cycle position of the last user warning is primarily displayed via the Wash progress LEDs. The 8 Wash progress LEDs correspond to the 8 stages of a Wash Cycle. Initially, all 8 Wash Cycle LEDs are illuminated and turn off from left to right as each wash stage is completed ie if the user warning was suds (in diagnostic mode 0) and the 1st Rinse LED was lit in this level, this was the stage in the cycle where the user warning occurred.

Diagnostic Mode 3: Fault Code of Last Fault (if within the last 8 Wash Cycles)

Also, sometimes referred to as the detailed fault code. The fault data is displayed via the Wash progress LEDs in binary* form (Refer to Section 5), this will relate to a fault code (fault codes are contained in section 7 of this manual). If there are no LEDs lit, a fault code hasn't occurred in the last 8 cycles.

Diagnostic Mode 5: Cycle Count at Last Fault (Low Byte).**Diagnostic Mode 6: Cycle Count at Last Fault (High Byte).**

The number of Wash Cycles since the last fault is displayed on the Wash Progress LEDs. The low byte refers to binary* numbers from 1 through to 128. The high byte refers to numbers from 256 through to 32768. Always check both the low and high bytes, and then add the two together to get the final result.

NB. Even though the last fault gets wiped from diagnostic level 3 after 8 cycles, the cycle number when the last fault occurs is permanently stored in the memory.

Diagnostic Mode 7: Cycle Position at Last Fault

The Wash Cycle position of the last fault is primarily displayed on the wash progress indicator. In addition to this, the exact stage of the wash where the fault occurred is displayed via the Wash Progress LEDs. The 8 Wash Progress LEDs correspond to the 8 stages of a Wash Cycle. Initially, all 8 Wash Progress LEDs are illuminated and turn off from left to right as each wash stage is completed.

Diagnostic Mode 8: Water Temperature (Degrees C)

The Wash Temperature (of the thermistor in °C) is displayed on the Wash Progress LEDs in binary* form. See Section 5.10 for the binary* conversion chart.

Diagnostic Mode 9: Cycle Count (Low Byte)**Diagnostic Mode 10: Cycle Count (High Byte)**

The number of Wash Cycles is displayed on the Wash Progress LEDs in binary* form. The low byte refers to binary* numbers from 1 through to 128. The high byte refers to numbers from 256 through to 32768. Always check both the low and high bytes, and then add the two together to get the final result.

Note: The wash cycle count is incremented at the end of the spin cycle.

Diagnostic Mode 11: Motor Speed (RPM)

The motor speed is displayed on the Wash Progress LEDs in binary* form. The current speed (RPM) can be calculated by totalling the binary* value of the Wash Cycle LEDs and multiplying this figure by 10.

Diagnostic Mode 12: Water Level

The water level is displayed on the Wash Progress LEDs in binary* form and can be calculated by totalling the binary* value of the Wash Progress LEDs and multiplying this figure by 2.

Diagnostic Mode 14: Motor Control Software Version

The motor control software version is displayed on the Wash Cycle LEDs in binary* form and can be calculated by totalling the binary* value of the Wash Cycle LEDs.

Diagnostic mode 15: Display Software Version

The display software version is displayed on the Wash Cycle LEDs in binary* form and can be calculated by totalling the binary* value of the Wash Cycle LEDs.

* Binary: To calculate a result displayed in binary form, (refer to section5.10)

5.8 Voltage Readings from the Controller

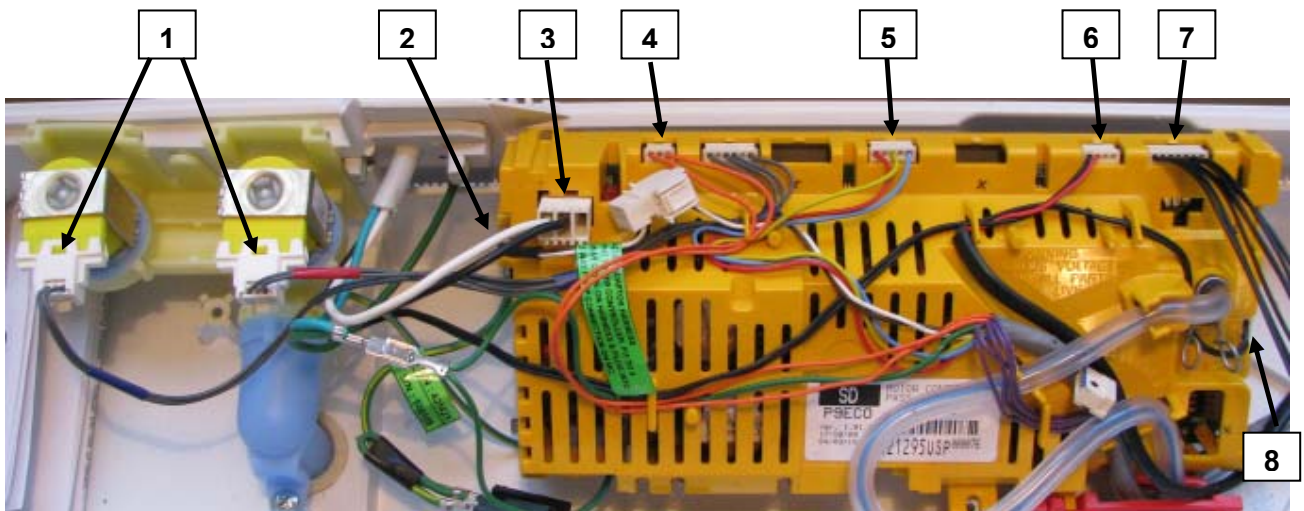

1. Water Valves
 Varies between 13 – 22V DC
Note: Accurate voltages can only be obtained by using a True RMS multimeter.

2. Pump Motor

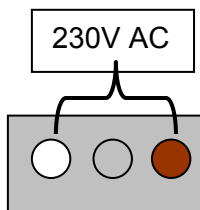

3. Supply Voltage
 230-240V AC

4. Recirculation Valve

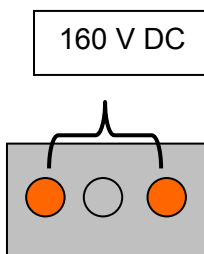

5. Wash Motor
 No accurate readings are possible

6. Lid lock

Pulses up to 30V when locking, when locked, sits at approx 10V DC

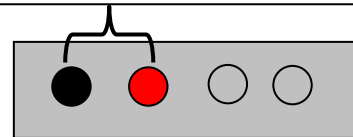

7. Display Module

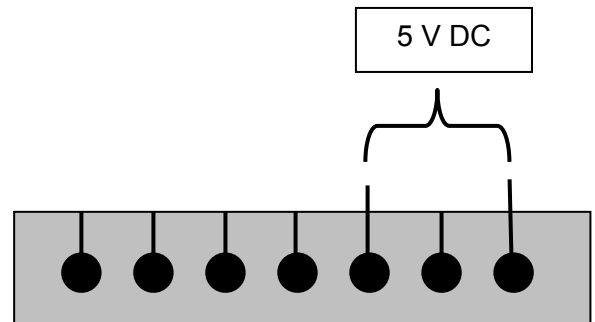

8. Thermistor

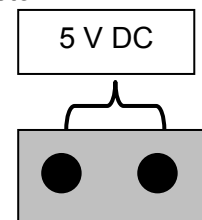

5.9 Resistance Readings from the Controller

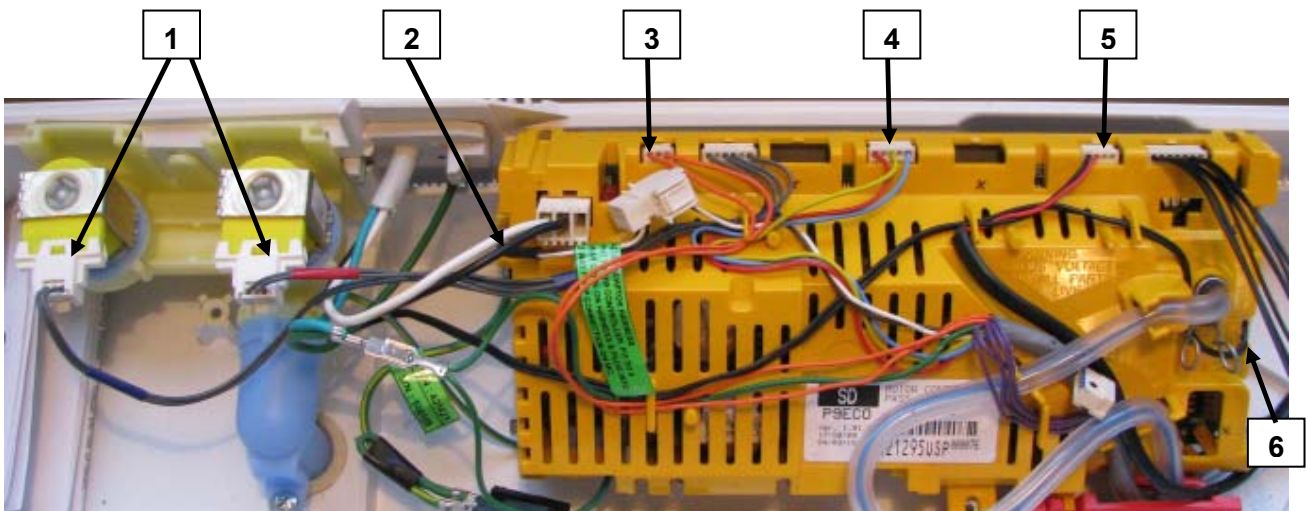

1. Water Valves
64 Ω +/- 10%

2. Pump Motor Selni

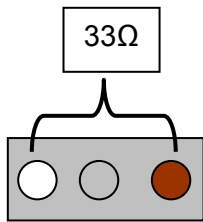

2. Pump Motor Hanning

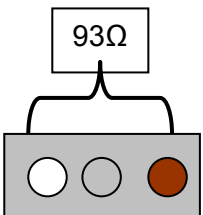

3. Recirculating Valve

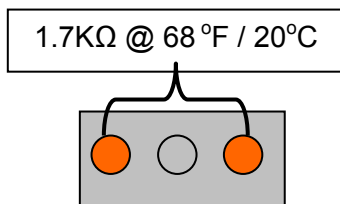

4. Wash Motor (Stator)

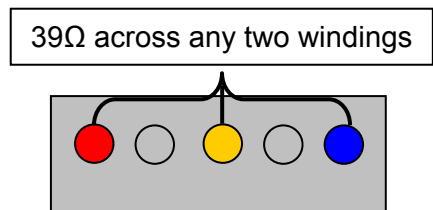

5. Lid Lock

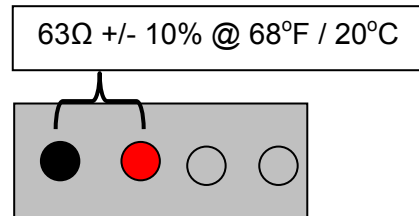

6. Thermistor

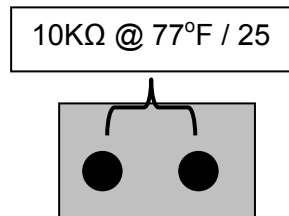

5.10 Binary Decoding Chart – 8 Bits (0-255) QuickSmart, WashSmart, MW, GW & WA

	000	001	010	011	100	101	110	111
00000	0	1	2	3	4	5	6	7
00001	8	9	10	11	12	13	14	15
00010	16	17	18	19	20	21	22	23
00011	24	25	26	27	28	29	30	31
00100	32	33	34	35	36	37	38	39
00101	40	41	42	43	44	45	46	47
00110	48	49	50	51	52	53	54	55
00111	56	57	58	59	60	61	62	63
01000	64	65	66	67	68	69	70	71
01001	72	73	74	75	76	77	78	79
01010	80	81	82	83	84	85	86	87
01011	88	89	90	91	92	93	94	95
01100	96	97	98	99	100	101	102	103
01101	104	105	106	107	108	109	110	111
01110	112	113	114	115	116	117	118	119
01111	120	121	122	123	124	125	126	127
10000	128	129	130	131	132	133	134	135
10001	136	137	138	139	140	141	142	143
10010	144	145	146	147	148	149	150	151
10011	152	153	154	155	156	157	158	159
10100	160	161	162	163	164	165	166	167
10101	168	169	170	171	172	173	174	175
10110	176	177	178	179	180	181	182	183
10111	184	185	186	187	188	189	190	191
11000	192	193	194	195	196	197	198	199
11001	200	201	202	203	204	205	206	207
11010	208	209	210	211	212	213	214	215
11011	216	217	218	219	220	221	222	223
11100	224	225	226	227	228	229	230	231
11101	232	233	234	235	236	237	238	239
11110	240	241	242	243	244	245	246	247
11111	248	249	250	251	252	253	254	255

The above table shows the 8 wash progress LEDs with the SPIN LED corresponding to the LED on the far right hand side.

8 bit binary calculations: Least Significant Byte (LSB) is the SPIN LED. If it is on this has a value of 1. The Most Significant Byte (MSB) is the first wash LED, this has a value of 128 if it is on. The intermediate LEDs have values of 64, 32, 16, 8, 4 and 2.

By adding up the value of all the LEDs that are illuminated the 8 bit binary value may be calculated.

Note: If the Spin LED is optically downloading it will be 'flickering', this does not necessarily count as part of the 8 bit value.

To calculate a 16 bit value (eg. cycle count) TOTAL = (high byte x256) + (low byte).

6 WIRING DIAGRAM

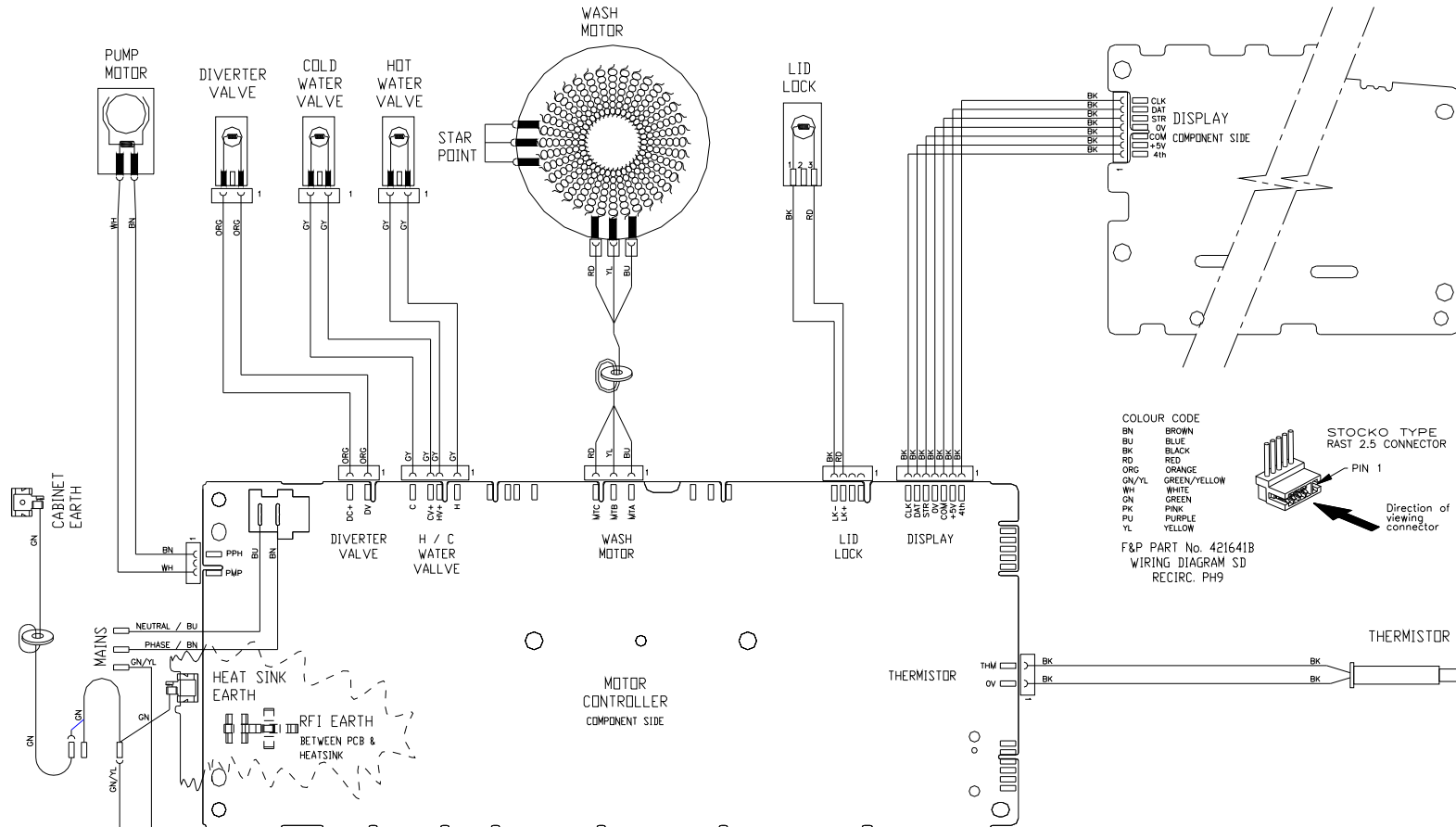

Resistance Table	
Water Valve	64Ω @ 20°C
Recirculating Valve	Between 700Ω and 2.5KΩ
Pump Selni	33Ω
Hanning	93 Ω
Lid Lock	63Ω +/- 10% @ 20°C
Thermistor	10KΩ @ 25°C
Stator	39Ω +/- 10%

7 DETAILED FAULT CODES

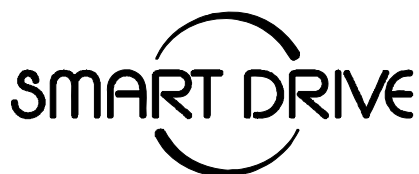

DETAILED FAULT CODES

INTRODUCTION

The format for fault description in this booklet follows the Primary, Secondary, Tertiary and Quaternary fault source system. These sources have mostly been arranged in order of most likely source of fault, but in some cases the sequence has been modified to aid the servicing procedure.

It should be noted that the fault source **Pump System** includes the pump and drain hose assembly.

These fault codes are specific to this series of machines.

Fault code shows the last recorded fault. Always confirm fault.

7.1 Fault Descriptions

1. (0000001) Motor Control Module Fault

The Motor Control Module has encountered an error when writing to an EEPROM address.

Primary Source: Motor Control Module.

Action: Replace Motor Control Module.

3. (0000011) Motor Control Module Fault

The Motor Control Module has found a memory error.

Primary Source: Motor Control Module.

Action: Replace Motor Control Module.

9. (0000100) Size Switch Error

The Display size setting is not set.

Action,: Reselect the size of the machine by using the SIZE SETTING MODE. To set the size, turn the power on at the power point and off at the console. Press and hold **Wash Temperature Up** button then press **Power** button until the machine gives 4 short beeps and the pattern of LEDs change.

- Press **Spin Speed Up** button, the **Spin Hold** LED should be on for the **7.5 / 8.0kg** (25.5in / 650mm wide).
- Press **Power** to confirm the setting and also exit this mode.

10. (00001010) Temperature Sensor (Thermistor) Error

The temperature sensor may be open circuit or the ambient temperature is below 14°F / -10°C.

Primary Source: Thermistor

Secondary Source: Motor Control Module

- Action:**
1. Check the connection of the thermistor to the Motor Control Module.
 2. Check resistance of temperature sensor. Resistance should be $10k\Omega @ 77^\circ F / 25^\circ C$ or $12.5k\Omega @ 68^\circ F / 20^\circ C$. Replace if faulty.
 3. Replace Motor Control Module.

12. (00001100) Flood Protection Error

The Motor Control Module has found the water level to be above the flood level and tried to pump the excess water out. (Under extremely high flow rate conditions the machine may overflow during the "top-up" routine in agitate.) After pumping for 30 seconds, it has been unable to lower the water level below the flood level. Either the water valves have stuck on and are letting water in at a flow rate that is higher than the pump can handle, or the pump is blocked and can't remove the excess water.

Primary Source: Water Valves.

Action: If the water valves are on continuously, check that the water valves turn off mechanically (remove power from machine).

Secondary Source: Pump system.

Action: Check the pump for blockages and drain hose for correct height and kinking

Tertiary Source: Motor Control Module.

Action: If water valves are being driven on electrically, replace Motor Control Module.

21 (00010101) Water Valve Over Current

The Motor Control Module has detected that the water valve circuit is drawing to high a current.

Primary Source: Water valves.

Action: Check that the resistance of the water valves are $64\Omega @ 68^\circ F / 20^\circ C$.

Secondary Source: Motor Control Module

Action: Replace the Motor Control module.

36. (00100100) Water Leak Fault

The Motor Control Module has needed to top up the water level more than 4 times during agitate. This is excessive, as normally only one or two top ups are required to replace the air that has escaped from a full load during agitate. The most likely cause is that the machine is siphoning. The other alternative is that the machine has developed a leak.

Primary Source: Pump System.

Action

- 1) Check the height of the drain hose outlet. Minimum 33.46in / 850mm, maximum 47.24in / 1200mm
- 2) Check that the hose guide is fitted and check that the hose does not protrude more than .78in / 20mm beyond the guide.

Secondary Source: Mechanical.

Action:

- 1) Check the pressure tube connections on the outer bowl and Motor Control Module.
- 2) Check that the drive shaft seal and the pump housing seal have not developed a leak.

Tertiary Source: Motor Control Module.

Action: Replace Motor Control Module.

37. (00100101) No change in the water level (Pump Blocked Error)

While draining, the water level reading from the pressure sensor has not changed for over 3 minutes. There are three likely reasons for this fault. One is that the drain hose or the pressure switch hose has been squashed or kinked and the pump out rate has been dramatically reduced. The second possibility is that the pump is partially or fully blocked. The third is that the pump is not operating due to Motor Control Module, wiring or pump failure. This fault could also appear if the machine is pumping to an unusually high head of drain hose or into an extended length of drain hose. The fourth possibility is a recirculation valve fault or blockage, water level is not altering as the recirculation valve is stuck in the recirculating mode, giving the module the appearance the pump is not lowering the water level.

Primary Source: Pump System.

Action:1)

Check that the drain hose has not been kinked.

2) Check the length of the drain hose and try to reduce the length if excessively long. A 39.36in / 1 metre extension hose of the same diameter fitted to the existing drain hose is the maximum allowable extra length.

3) Check for open circuit windings in the pump. (**Note: Pumps are fitted with a thermal cut-out, which will reset on cooling.**)

4) If the bowl is empty of water, remove the pump from the pump housing and check that it is not blocked. Also check the drain hose is not blocked.

5) If the bowl contains water, then service the pump from the top of the machine by removing the top deck and inner bowl. Bail out the water, remove the pump cap and hood and clear the restriction.

Secondary Source: Wiring.

Action:

1) Check the pump harness is connected correctly to the pump.

2) Check continuity of the pump harness.

Tertiary Source: Motor Control Module.

Action:

Activate the pump by using the diagnostics mode or operating the machine in spin mode. Check the pump is rotating. If it is not operating, and Primary and Secondary checks have been performed, then replace the Motor Control Module.

38. (00100110) Pressure Sensor Fault

The Motor Control Module has recorded a water level of empty while it is agitating. The water level must have been greater than empty for the machine to enter the agitate mode initially. The most likely cause of this fault is that the pressure sensor hose has been severed or fallen off during agitate. Alternatively, the pressure sensor may be faulty.

Primary Source: Mechanical.

Action:

Check that the pressure tube is intact and has not been cut.

Secondary Source: Motor Control Module.

Action:

Replace the Motor Control Module if the pressure tube shows no sign of being faulty.

39. (00100111) Pressure Tube Fault

The probable cause of this fault is that the pressure tube has become blocked or kinked or has fallen off completely. Alternatively, the pressure sensor may be faulty.

Primary Source: Mechanical.

Action:

Check that the pressure tube is intact and not blocked with water or dirt and is not kinked.

Secondary Source: Motor Control Module.

Action:

Replace the Motor Control Module.

40. (00101000) Inner Bowl Disengage Fault

While carrying out a bowl check, the Motor Control Module has found that the bowl is not engaged even though the pressure sensor indicates that the bowl is empty. The Motor Control Module continues to check for 2 minutes, after which time it displays this fault. The first two areas to check are the clutch and the pressure tube. If these two appear correct, then the fault could be in the pressure sensor in the Motor Control Module.

Primary Source: Mechanical.

Action: 1) Check that there are no clothes or other foreign objects preventing the clutch from re-engaging. Excessive suds can stop the bowl rotating.

2) If the machine is empty of water, carry out a clutch disassembly procedure (Refer to section 8.15) and check the spline drive.

3) Next check that the pressure tube has not come off and that it is not kinked.

Secondary Source: Motor Control Module.

Action: Replace Motor Control Module.

41. (00101001) Temperature Sensor Fault (Thermistor)

The temperature sensor is measuring temperatures above 230°F / 110 °C. The fault is probably due to a short circuit in the sensor line.

Primary Source: Thermistor.

Action: 1) Check the connection from the thermistor to the Motor Control Module

2) Check the resistance of the thermistor. Resistance should be 10kΩ @ 77 °F / 25°C or 12.5kΩ @ 68°F / 20°C. Replace if faulty.

Secondary Source: Motor Control Module.

Action: Replace Motor Control Module.

45. (00101101) Display Memory Check Fault

On power up, the display has checked its memory against a known reference and found differences.

Primary Source: Display Module.

Action: Replace Display Module.

46 (00101110) Display Memory EEPROM check Fault.

The Intuitive™ Display has detected a problem with its internal EEPROM.

Primary Source: FabricSmart IW Display Module.

Action: Replace FabricSmart IW Display Module.

48. (00110000) Hot and Cold Valve Coil Faulty

The Motor Controller module has measured voltages from the valve diagnostic circuit that indicate both the hot and cold valves are faulty. The most likely cause is that the valve harnesses have not been connected correctly or the valve is open circuit.

Primary Source: Wiring.

Action: Check the valve harnesses are correctly fastened to the valves or the pins are not bent backwards.

Secondary Source: Water Valves.

Action: Check the valve coils are not faulty (open circuit).

Tertiary Source: Motor Controller module.

Action: Replace the Motor Controller module.

49. (00110001) Cold Valve or Cold Valve & Hot Valve Faulty

The Motor Control Module has measured a voltage from the valve diagnostic circuit that indicates the cold valve or both the hot and cold valves are open circuit. The most likely cause is that the valve harness has not been connected correctly or the valve(s) is open circuit. See fault 48 for service procedure.

Primary Source: Wiring.

Action: Check the valve harnesses are correctly fastened to the valves and the Motor Control Module, or the pins are not bent backwards. If possible, test the harness for continuity between the valve end of the harness and the Motor Control Module end of the harness.

Secondary Source: Water Valves.

Action: Measure the resistance of the Hot and Cold valve coils.

Tertiary Source: Motor Control Module.

Action: Replace the Motor Control Module.

50. (00110010) Hot Valve Coil Faulty

The Motor Control Module has measured a voltage from the valve diagnostic circuit that indicates the hot valve is faulty. The most likely cause is that the valve harness has not been connected correctly or the valve is open circuit. See fault 48 for service procedure.

51. (00110011) Recirculation Valve Fault

The motor controller has registered a drop in water level in the recirculation phase of the wash cycle. Water is being drained instead of recirculated.

Primary Source: Recirculating valve.

Action: Remove the recirculating valve and check for blockages as well as checking that the hinge mechanism on the valve hasn't broken. Remove the hinge from the solenoid and check that the flap is free to move. Check that the water hasn't been sprayed onto the valve from an external source and caused the solenoid to blow.

Secondary Source: Wax solenoid

Action: Check the resistance of the wax solenoid. Also look for corrosion (greenish deposit) on the terminals. Resistance range will be between 0.7k Ω and 2.5k Ω . Resistance will depend on ambient temperature and when the valve was last actuated. Anything outside of these resistances and the valve should be automatically replaced.

Tertiary Source: Motor Control Module.

Action: Turn the power off at the machine but leave the power on at the wall, then measure the voltage across the terminals of the wax actuator. If a reading of 120V is achieved, the motor controller has failed due to a valve fault and both will need to be replaced.

52. (00110100) Recirculation Top-up Fault

More than 6 attempts have been made to top-up the water level in the bowl. This then signifies the valve has not closed and is draining, or the top-up was not increasing quickly enough, suggesting the valve has a blockage and is also draining.

Primary Source: Recirculation valve.

Action: Remove the recirculating valve and check for blockages as well as checking that the hinge mechanism on the valve hasn't broken. Remove the hinge from the solenoid and check that the flap is free to move.

Secondary Source: Wax solenoid

Action: Check the resistance of the wax solenoid. Also look for corrosion (greenish deposit) on the terminals. Resistance range will be

between 0.7k Ω and 2.5k Ω . Resistance will depend on ambient temperature and when the valve was last actuated. Anything outside of these resistances and the valve should be automatically replaced.

56. (00111000) Inner Bowl Check Not Valid Fault

While carrying out a bowl check, the machine has not been able to determine a valid bowl status and so the Display flags this fault. This fault differs from fault 40 in that a valid bowl status could not be determined.

Primary Source: Loading.

Action: Remove items until the remaining ones can move freely, or rearrange the load so that the clothes are evenly distributed around the bowl, or select a higher water level. If the load was to one side of the bowl or too heavy, it can be possible for the agitator to bind in one direction when trying to sense bowl float.

Secondary Source: Mechanical.

Action:

1. Check the machine is not siphoning.
2. Check that there are no clothes or other foreign objects preventing the clutch from re-engaging, and that there aren't any defects with the clutch mechanism.
3. Check that the pressure tube has not come off and that it is not kinked.

Tertiary Source: Motor Control Module.

Action: Replace the Motor Control Module.

57. (00111001) Brown Out During Display EEPROM Write Fault

The Display has requested the Motor Control Module to perform an EEPROM write. Prior to writing, the Motor Control Module has tested the 15 Volt supply and found that it is below the safety level for writing EEPROM and has reported this to the Display. This may be due to transients at the time of writing or due to a faulty Motor Control Module.

Primary Source: Motor Control Module.

Action: Replace Motor Control Module.

60. (00111100) Motor Control Memory Check Fault

On power up, the Motor Control Module has checked its memory against a known reference and found differences.

Primary Source: Motor Control Module.

Action: Replace Motor Control Module.

68. (01000100) Pressure Transducer Error – Count Too High

The pressure transducer has measured a water level far above what the machine should physically be able to measure. This suggests that the pressure sensor has been disconnected from the Motor Control Module, damaged or not actually placed on the PCB.

Primary Source: Motor Control Module.

Action: Replace Motor Control Module.

69 (01000101) Pressure Transducer Error – Zero Too Low

The pressure sensor is zeroed in the factory, but to compensate for zero-drift during the life of a product the zero is adjusted at the end of each cycle if required. The product only zeros the pressure sensor once, on first power up when the Pressure Transducer EEPROM locations are out of the expected zero bounds. During the zeroing process if the zero value is below what is expected then fault code 69 is flagged.

Primary Source: Motor Control Module.

Action: Replace Motor Control Module.

- 70. (01000110) Pressure Transducer Error – Zero Too High**
 Similar to fault code 69, however, it protects against a zero, which is too high and could cause flooding.
Primary Source: Motor Control Module.
Action: Replace Motor Control Module.
- 72. (01001000) Pressure Transducer Error – Maximum Positive Drift**
 Over the life of a product it is expected that the pressure transducer characteristics will drift slightly. To compensate for this the zero is re-calibrated at the end of every cycle. If this zero is significantly different to the original factory programmed zero then fault code 72 is flagged.
Primary Source: Motor Control Module.
Action: Replace Motor Control Module.
- 73. (01001001) Pressure Transducer Error**
 An incorrect pressure transducer has been fitted to the machine
Primary Source: Motor Control Module.
Action: Replace Motor Control Module.
- 74. (01001010) Pressure Transducer Error**
 The pressure transducer frequency is out of range
Primary Source: Motor Control Module.
Action: Replace Motor Control Module.
- 104. (01101000) See Fault Code 106**
- 105. (01101001) Comms Error Time Out**
 These faults are reported when the Display Module detects an error in the communications between the Display Module and the Motor Control Module. Can also occur when the display is change with the power still on.
Primary Source: Display Module.
Action: Replace Display Module.
Secondary Source: Motor Control Module.
Action: Replace Motor Control Module.
- 106. (01101010) Display Module to Motor Control Module Communications Error**
 These faults are reported when the Display Module detects an error in the communications between the Display Module and the Motor Control Module.
Primary Source: Display Module.
Action: Replace Display Module.
Secondary Source: Motor Control Module.
Action: Replace Motor Control Module.
- 107. (01101011) Motor Control Module Reset Error**
 The Display Module has detected that the Motor Control Module has reset when it should not have. This can be due to a Motor Control Module supply disturbance or microprocessor failure.
Primary Source: Motor Control Module.
Action: Replace Motor Control Module.
- 108. (01101100) Comms CRC Error – See Fault Code 106**

109. (01101101) AC Pump Triac Over Temperature

This fault occurs when the electronics have detected that the temperature of the pump Triac has exceeded what would be expected under normal conditions. The most likely cause of this is that the pump has gone low in resistance.

Primary Source: Pump

Action: Check the pump resistance (Refer to Section 2.6)

Secondary Source: Motor Control Module.

Action: Replace Motor Control Module.

110. (01101110) Motor Bridge Thermistor Open Circuit

The motor bridge thermistor has been detected as open circuit. This means that the Motor Control Module can no longer monitor motor bridge temperatures. This suggests that the motor bridge thermistor has been damaged or removed from the PCB.

Primary Source: Motor Control Module.

Action: Replace Motor Control Module.

111. (01101111) Motor Bridge Thermistor Short Circuit

Similar to Fault Code 110, however instead of detecting an open circuit, the motor bridge thermistor has been detected as being short circuit.

Primary Source: Motor Control Module.

Action: Replace Motor Control Module.

112. (01110000) Motor Current Sense Too High

This fault occurs if the Motor Control Module detects that the motor current has reached an unrealistically high level for greater than 2 seconds. This suggests that the motor current sense circuit is faulty.

Primary source: Motor Control Module.

Action: Replace Motor Control Module.

113. (01110001) AC Pump Thermistor Short Circuit

The AC Pump thermistor has been detected as being short circuit. This means that the Motor Control Module can no longer monitor AC pump Triac temperatures correctly.

Primary source: Motor Control Module.

Action: Replace Motor Control Module.

133. (10000101) Repetitive Current Trip

The Motor Control Module has detected excess current in the motor or electronic switches. This fault is a more severe occurrence than fault code 132 but has identical fault sources and fault service procedure

136. (10001000) Motor Stall

The Motor Control Module has been unable to start the motor. Possible causes of this fault are: Faulty motor harness, faulty or jammed motor, seized bearings or seals, faulty Motor Control Module.

Primary Source: Wiring.

Action: Measure/check the motor harness, connectors and motor for continuity. This can be done by taking a resistance measurement between phases of the motor harness at the Motor Control Module end. Nominal resistance should be around 39Ω.

Secondary Source: Motor.

Action: 1) Check free rotation of the agitator and bowl by rotating by hand. Bearings and seals may be seized.

Tertiary Source: Motor Control Module.

Action: If the primary and secondary checks pass inspection, then replace the Motor Control Module.

137 (10001001) Motor loss of a Phase

The Motor Control Module has detected the loss of one of the phases of the motor. Possible causes of this fault are: Faulty motor harness, an open circuit winding of motor or faulty motor controller.

Primary Source: Wiring

Action: Measure/check the motor harness, connectors and motor for continuity. This can be done by taking a resistance measurement between phases of the motor harness at the Motor Control Module end. Nominal resistance should be around 39Ω.

Secondary Source: Motor.

Action: Remove Stator and measure/check the resistance of each winding which is approximately 19.5Ω.

Tertiary Source: Motor Control Module.

Action: If the primary and secondary checks pass inspection, then replace the Motor Control Module.

160. (10100000) Bowl Engaged In Agitate

The bowl has re-engaged itself during agitate. Possible causes for this are a leak in the air bell, the bowl is over-loaded with clothes, the clutch has jammed or is fouled with a foreign object.

Primary Source: Mechanical.

Action:

- 1) Check that the rotating bowl assembly is not jammed to the agitator with any foreign object that may be caught under the agitator skirt.
- 2) Check that the clutch teeth are not locked together with dirt, lint, etc.
- 3) Make sure the bowl is not overloaded with too many clothes.
- 4) If none of the above appears to be at fault, then check the air bell at the bottom of the outer bowl for leaks.

Secondary Source: Motor Control Module.

Action: If the machine is empty of water at fault, it is possible that the pump circuit is faulty and has caused a pump out during wash. This would cause the bowl to re-engage during agitate and the Motor Control Module to display this fault. Replace Motor Control Module.

220. (11011100) EEPROM Model Map Not Programmed

Similar to fault code 60

Primary Fault: Motor Control Module.

Action: Change Motor Control Module.

221 (11011101) Motor Control Module Fault

The motor control has encountered a RAM check error

Primary Fault: Motor Control Module.

Action: Change Motor Control Module.

222 (11011110) Motor Control Module Fault

The motor control has encountered a Stack error

Primary Fault: Motor Control Module.

Action: Change Motor Control Module.

223 (11011111) Motor Control Module Fault

The motor control has encountered a program counter error

Primary Fault: Motor Control Module.

Action: Change Motor Control Module.

421827

224 (11100000) Motor Control Module Fault

The motor control has encountered a peripheral error

Primary Fault: Motor Control Module.

Action: Change Motor Control Module.

225 (11100001) Motor Control Module Fault

The motor control has encountered a clock error

Primary Fault: Motor Control Module.

Action: Change Motor Control Module.

230. (11100110) EEPROM Value out of Range

Wrong version detected

Primary Fault: Motor Control Module is the wrong version.

Action: Change Motor Control Module.

232. (11101000) COMMS Timeout 5 Seconds

FabricSmart IW only problem, either the Display or Motor Control Module has not responded in time.

Primary Fault: Display Module.

Action: Replace Display Module.

Secondary Fault: Motor Control Module.

Action: Replace Motor Control Module.

233. (11101001) EEPROM Read Error

Problem in reading the EEPROM data, coming from the Motor Control Module

Primary Fault: Motor Control Module fault.

Action: Replace Motor Control Module.

234. (11101010) Lid Lock Open Circuit

Check harness to Lid Lock, the connections at the Motor Control Module and lid lock ends.

Primary Fault: Connectors on the harness at either end could be at fault.

Action: Replace Lid lock assembly.

Secondary Source: Lid lock has failed to be activated.

Action: Replace Lid Lock Assembly.

Tertiary Source: Motor Control Module has not responded to the lid lock being activated.

Action: Check the lid has a tang and is fitted correctly to activate the lid lock. If this is all in order, the Motor Controller must be faulty and needs replacing.

235. (11101011) Lid Lock Short Circuit

Lid Lock fault, not activated when instructed to by the Motor Control Module.

Primary Fault: Lid Lock mechanism has jammed or failed.

Action: Check resistance across the connections, this should be 63 ohms +/- 10% @ 20 °C. If faulty, replace the Lid Lock assembly.

236. (11101100) Incompatible EEPROM Version.

Failed to start with fault being immediately displayed

Primary Fault: Motor Control Module is wrong one.

Action: Fit correct Motor Control Module.

237. (11101111) Temperature Sensor Error

The electronics have picked up a continuity problem, the same as fault code 10 or 40.

Primary Fault: The sensor has failed either in the harness or the connection to the thermistor.
Action: Replace the thermistor (temperature sensor).
Secondary Source: Motor Control module has failed to read the temperature. Check connections.
Action: Replace Motor Control Module if the connections look fine and the fault still occurs.

238. (11101010) Lid Lock Open Circuit

Check Harness to Lid Lock and connections at the Motor Control Module and lid lock ends.
Primary Fault: Connector to the harness, either end could be at fault.
Action: Replace Lid lock assembly.
Secondary Source: Lid Lock has failed to be activated.
Action: Replace Lid Lock.
Tertiary Source: Motor Control Module has not responded to the Lid Lock being activated.
Action: Check the lid has a tang and is fitted correctly to activate the Lid Lock. If this is all in order, the Motor Control Module must be at fault and needs to be replaced.

239. (11101011) Lid Lock Short Circuit

Lid Lock fault, not activated when instructed to by the Motor Control Module.
Primary Fault: Lid Lock mechanism has jammed or failed.
Action: Check resistance across the connections. If out of specification, replace the Lid Lock, ($63\Omega \pm 10\%$ @ 20°C (68°F))

241. (11110001) Function Time Out

Display crashed.
Primary Fault: Display Module has failed.
Action: Replace Display Module.
Secondary Fault: Motor Control Module has failed.
Action: Replace Motor Control Module.

243. (11110011) Stepper Test Failure

The Motor Control Module has attempted a motor step test and found the motor has not stepped to the correct position.
Primary Source: Wiring.
Action: Check the continuity of the Motor Harness and that the connectors are correctly applied to the Motor and Motor Control Module.
Secondary Source: Motor.
Action: Check continuity of motor phases. Check the bridge terminal on the stator is not open circuit or burnt. Replace Stator.
Tertiary Source: Motor Control module.
Action: Replace the Motor Control Module

252. (11111100) Motor Bridge Test Failure

The Motor Control Module has tested the motor bridge electronics and sensed current when there should not have been any.
Primary Fault: Motor Control Module
Action: Replace Motor Control Module

254 (11111110) Motor Control Version to Old

The Motor Control Module software version is too old for the display to support.
Primary Fault: Motor Control Module
Action: Replace Motor Control Module

8 SERVICE PROCEDURES

In order to service and to gain access to components within the machine, certain procedures must be followed. These procedures are set out below.

Servicing note

- (a) To avoid stripping screws, do not over tighten when re-assembling parts. If using a power screwdriver, have the torque setting on low.
- (b) Take care not to damage wire terminals on removal as some of these have release clips.
- (c) On completion of any service carried out to the washing machine, all safety tests as required by law must be carried out.

8.1 Removal of Lid

- (a) Open the lid fully and then lift off vertically.

Reassembly

Refit in reverse manner, ensuring that the hinge lugs on the lid are vertical.



8.2 Components in Console Area

- (a) Remove the lid. (Refer to Section 8.1).
- (b) Remove the two screws at the rear of the console securing the console to the top deck.
- (c) Tilt the console forward.

Reassembly:

Refit in reverse manner.

8.3 Removal of Display Module QuickSmart, WashSmart, MW, GW & WA

- (a) Follow instructions for removal of console. (Refer to Section 8.2).
- (b) Disconnect the display wiring harness from the Motor Control Module.
- (c) Unclip the 6 tabs to release the circuit board.
- (d) Lift the display module clear of the console.

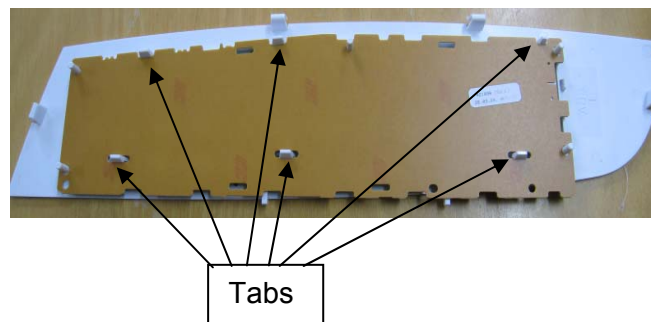

Reassembly:

Refit in reverse manner.

8.4 Removal of Display Module FabricSmart IW

- (a) Follow instructions for removal of console. (Refer to Section 8.2).
- (b) Disconnect the wiring harness from the motor control module
- (c) Remove the 4 screws securing the display module to the console
- (d) Remove the display module from the housing by pivoting the display away from the console

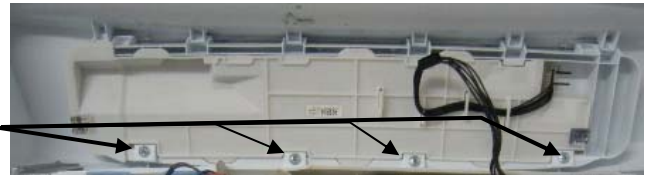

Reassembly:

Refit in the reverse manner

8.5 Removal of Water Valves

- (a) Follow the procedure for removal of Console. (Refer to Section 8.2).
- (b) Disconnect the Display wiring harness from the Motor Control module & place console out of the way.
- (c) Disconnect wiring harness to each coil by first pulling downwards on the retaining clip.
- (d) Disconnect Thermistor harness from the Motor Control module.
- (e) Remove screw securing the outlet nozzle to the top deck.
- (f) Pull upwards on the spigot to release the nozzle from the seal in the top deck. As soon as the seal is broken most of the residual water will drain from the nozzle. Remove the water valves from the top deck ensuring no water comes in contact with any electrical connections.

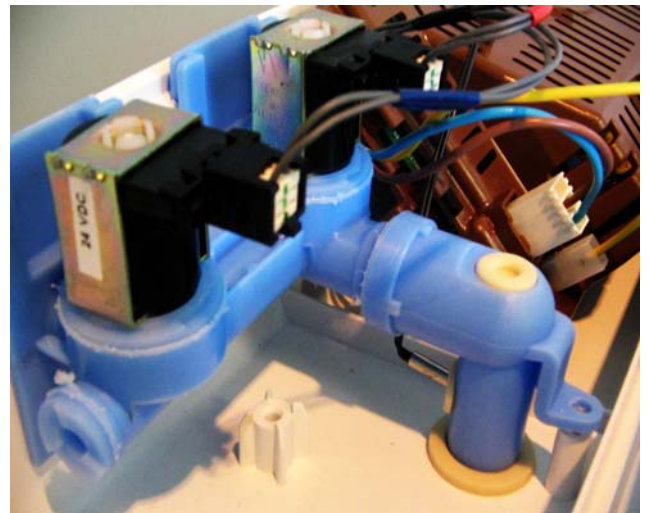

Reassembly:

Refit in reverse manner.

8.6 Removal of Recirculating Valve

The Recirculating valve is situated at the bottom of the outer bowl beside the pump. If the valve requires service, remove the hose clips (3) connecting the hoses to the valve, and remove the screwed clamp around the drain hose to the valve. The valve now can be removed for cleaning or checking. This is best achieved by working from underneath the machine.

Reassembly:

Refit in reverse manner, ensuring that the Valve orientation is correct with the drain outlet connected to the drain hose. Flapper will have the Recirculation outlet in the closed position.



8.7 Removal of Thermistor

- Follow the procedure for removal of Console. (Refer to Section 8.2).
- Disconnect the Display wiring harness from the Motor Control module & place console out of the way.
- Disconnect thermistor-wiring harness to the Motor Control Module.
- Slide body of thermistor out from the valve.

Reassembly:

Refit in reverse manner, ensuring when refitting the thermistor that the thermistor is pushed in until it comes to a stop against the back wall of the elbow.

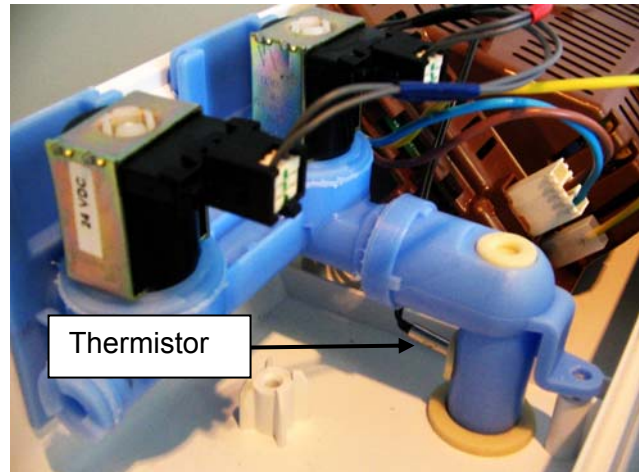

8.8 Removal of Motor Control Module

- Follow the procedure for removal of Console. (Refer to Section 8.2).
- Disconnect the Display wiring harness from the Motor Control module & place console out of the way.
- Disconnect all remaining wiring harnesses to the Motor Control Module.
- Remove the pressure tube by squeezing on the legs of the spring clip. Pull gently on the tube to slide it off the spigot.

Note: If too much force is used on removal or reinsertion, damage to the pressure transducer may occur.

- Remove the screw holding the Motor Controller from the front edge. Pull the tab on the top deck harness clamp towards the front to release the Motor Control Module.
- Lift the Motor Control Module upwards at the front and out.



Reassembly:

Refit in reverse manner. **Important:** When refitting the pressure tube to pressure transducer ensure that the pressure tube is clear of any water droplets before operating the machine on a fill cycle. If the bowl is full of water, drain the water then blow down the tube.

8.9 Removal of Cord Set

- (a) Follow the procedure for removal of water valves. (Refer to Section 8.5).
- (b) Disconnect the mains plug to the Motor Control Module.
- (c) Slide the strain relief to the left and slide out.

Reassembly:
Refit in reverse manner.

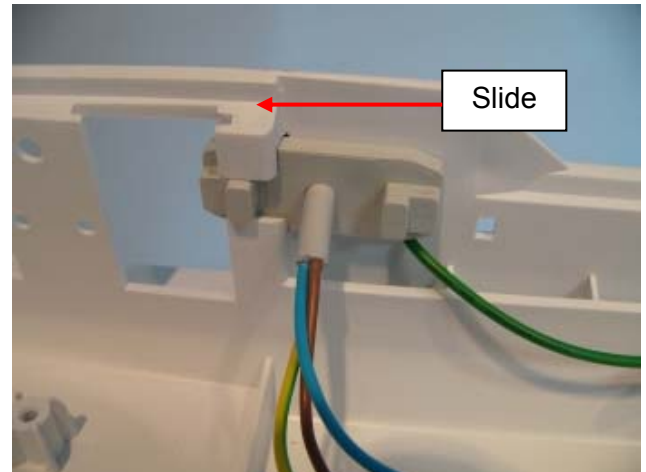

8.10 Removal of Lid Lock

- (a) Follow the procedure for removal of console. (Refer to Section 8.2).
- (b) Disconnect the Display wiring harness from the Motor Control module & place console out of the way.
- (c) Disconnect lid lock wiring harness at the Motor Control Module.
- (d) Remove Motor Control Module from the top deck (Refer to Section 8.8).
- (e) Remove wiring cover from rear right hand corner of top deck.
- (f) Carefully remove the two lid buffers from the front left & right side of the top deck by levering upwards, taking care not to damage the top deck.
- (g) Remove the two screws under the buffers securing the top deck to the cabinet.
- (h) Lift the top deck upwards and remove the screw securing the lid lock to the underside of the top deck. Move the front of the lid lock downwards and outwards.
- (i) Unclip the right hand rear tab of the top deck from the cabinet and raise the corner of the top deck upwards slightly to allow the wiring harness to be removed.

Reassembly:
Refit in the reverse manner.

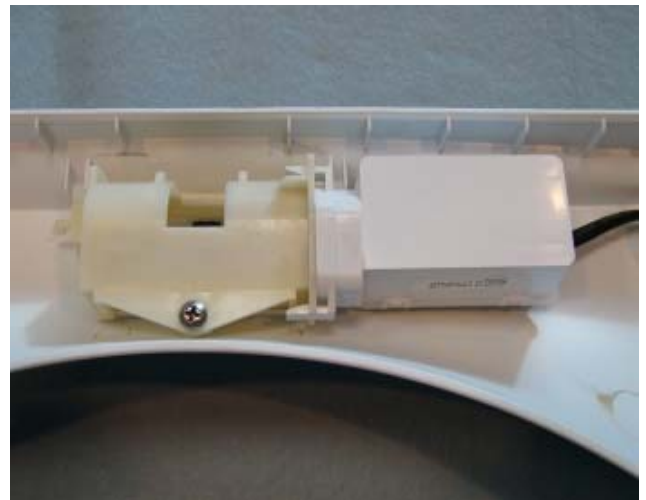

8.11 Removal of Top Deck

- (a) Follow the procedure for removal of console. (Refer to Section 8.2).
- (b) Disconnect the Display wiring harness from the Motor Control module & place console out of the way.
- (c) Follow the procedure for removal of water valves. (Refer to Section 8.5).
- (d) Follow the procedure for removal of Motor Control Module. (Refer to Section 8.8).
- (e) Follow the procedure for removal of cord set. (Refer to Section 8.9).
- (f) Remove wiring cover from rear right hand corner of top deck.
- (g) Carefully remove the two lid buffers from the front left & right side of the top deck by levering upwards, taking care not to damage the top deck.
- (h) Remove the two screws under the buffers securing the top deck to the cabinet.
- (i) Lift the front edge of the top deck upwards and release the two rear tabs.
- (j) Lift the top deck clear.



Reassembly:

Refit in reverse manner.

Note: *The inlet nozzle can be removed when the top deck is lifted.*

8.12 Removal of Neck Ring

- (a) Follow the procedure for removal of lid. (Refer to Section 8.1).
- (b) Carefully remove the two lid buffers from the front left & right side of the top deck by levering upwards, taking care not to damage the top deck.
- (c) Remove the two screws under the buffers securing the top deck to the cabinet.
- (d) Lift the front edge of the top deck upwards and tilt backwards.
- (e) Release the bias spring from the front left suspension rod.
- (f) Unclip the neck ring from the outer bowl and remove.



Reassembly

Refit in reverse manner

8.13 Removal of Agitator

- (a) Lift lid.
- (b) Remove fabric softener dispenser.
- (c) Release the agitator bolt by turning ant-clockwise.
- (d) Lift agitator out and clear.

Reassembly:

Refit in the reverse manner.

8.14 Removal of Inner Bowl

- (a) Follow the procedure for removal of Neck Ring. (Refer to Section 8.12).
- (b) Follow the procedure for removal of Agitator. (Refer to Section 8.13).
- (c) Lift inner bowl upwards and clear of machine.

Note: *If the inner bowl is tight on the shaft pressure may need to be placed on the top of the shaft, while at the same time jiggling the inner bowl upwards.*

Reassembly:

Refit in the reverse manner.

8.15 Removal of Clutch Mechanism (Spline Drive / Spline Driven)

- (a) Follow the procedure for removal of Inner Bowl. (Refer to Section 8.14).
- (b) Remove the 3 screws securing the spline driven to the inner bowl.

Reassembly:

Refit in the reverse manner. Ensure that the screws are tightened sufficiently with out over tightening.



8.16 Removal of Selni Pump Hood & Cap

- (a) Follow the procedure for removal of Inner Bowl. (Refer to Section 8.14).
- (b) Remove the bolt securing the pump hood to outer bowl.

Reassembly:

Refit in the reverse manner. Ensure that the gasket is not pinched between the pump hood and outer bowl.



8.17 Removal of Hanning Pump Hood

- (c) Follow the procedure for removal of Inner Bowl. (Refer to Section 8.14).
- (d) Remove the bolt securing the pump Hood to the outer bowl.

Reassembly:

Refit in the reverse manner. Ensure that the gasket is not pinched between the pump hood and outer bowl.



8.18 Removal of Outer Bowl from the Cabinet

- (a) Follow the procedure for removal of the Top Deck. (Refer to Section 8.11).
- (b) Follow the procedure for removal of Inner Bowl. (Refer to Section 8.14).
- (c) Thread the drain hose back in to the cabinet.
- (d) Remove the screw securing the drain hose fixture to the cabinet.
- (e) Press tab and rotate fixture carefully so remaining tabs clear the cabinet.



- (f) Remove all four suspension rods, by lifting upwards on the top suspension bracket. Start with the suspension rod that attaches to the drain hose / wiring assembly, and then do the opposing side.

Note: The pressure tube linkage will need to be unclipped from the suspension rod first.

- (g) With the suspension rods removed from the cabinet carefully lift the outer bowl assembly out of the cabinet, taking care not to cut the drain hose on any sharp edges of the cabinet.



Reassembly:

Refit in reverse manner.

8.19 Removal of Rotor

- Tilt the rear of the machine carefully against the wall ensuring that the machine is stable and locked in position; take necessary precautions not to damage the wall or the machine.
- Using 16mm or 5/8" socket, loosen Rotor bolt. As the Rotor bolt is loosened, the Rotor will withdraw off the base of the main shaft.

Note: Place the Rotor in a plastic bag as the Rotor has very strong magnets and can attract fine metal objects.

Reassembly

Refit in reverse manner. Tighten the Rotor bolt to a torque of **8-10Nm**.



8.20 Removal of Stator

- Follow the procedure for removal of Rotor. (Refer to Section 8.19).
- Unscrew the four bolts securing the Stator to the outer bowl.
- Lift Stator off the base of the outer bowl and clear of the shaft.
- Disconnect the wiring to the terminals.

Reassembly:

- Connect the wires to the Stator before locating the Stator on to the outer bowl. Ensure that the correct color wire is fitted to the correct terminal. The Stator is marked RBY (Red, Blue, and Yellow).
- Ensure that there is a small amount of grease spread evenly on the Stator side of the clamp plates.
- Fit the four bolts and only tighten to a torque of **5-7Nm**.

Note: The Stator should have a slight radial movement of approximately 0.5 – 1mm when correctly tightened, and should have a maximum axial (rocking movement) of 0.5mm.



8.21 Removal of Pump

Note: Approximately 250mls of water remains in the pump sump after pump out and will spill when the pump is removed. Take care not to spill this water over electrical connections by using a towel or small container to catch the water

8.21.1 Selni

- (a) Tilt the rear of the machine carefully against the wall ensuring that the machine is stable and locked in position; take necessary precautions not to damage the wall or the machine.
- (b) Remove the wiring harness and earth wire to the pump.
- (c) Release the locking tab by pulling it away from the pump. Keep pressure on the tab and turn the body of the pump in an counter-clockwise direction. Continue to turn until the pump disengages.

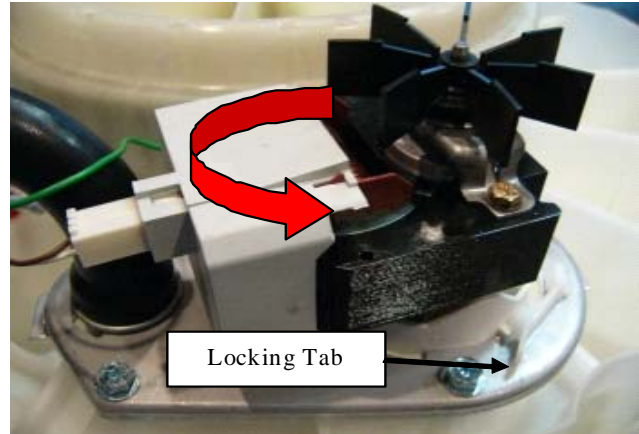

Reassembly:

- (a) Lubricate the seal face with liquid soap or detergent (do not use grease).
- (b) Locate the bayonet fixture correctly, and then turn the pump in a clockwise direction until you hear the locking tab clicks into place.
- (c) Connect the earth wire ensuring that the tab is locked into place by applying gentle pressure on the wire.
- (d) Connect main harness. Ensure that the wiring is routed correctly and will not foul on any moving components.

8.21.2 Hanning

- (a) Tilt the rear of the machine carefully against the wall ensuring that the machine is stable and locked in position; take necessary precautions not to damage the wall or the machine.
- (b) Remove the wiring harness to the pump with the aid of a small slot screw driver. Insert the screw driver into the terminal cover slot and lever the connector out carefully.
- (c) On recirculating product remove the associated **clamps**, at the bowl end of the pump to bowl hose and at the pump outlet of the pump to diverter valve hose and continue with step (e).
- (d) On non recirculating product remove the associated **clamps**, at the bowl end of the pump to bowl hose and at the drain hose connection of the pump.
- (e) Release the pump from the bottom of the tub by loosening off the rear screw and removing the 2 front screws that hold the pump bracket to the bowl.

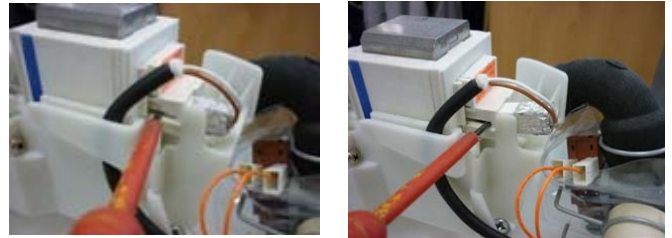

While releasing the pump to bowl hose from the bowl slide the bracket towards the front of the machine until the bracket is free of the rear screw. Then remove the hose connected to the pump outlet.



Reassembly:

- (a) On non recirculating product, refit the drain hose, ensure that it is refitted through the hose guide bracket, and clamp.
Taking care to not damage or puncture the drain hose with the hose guide bracket.
- (b) For recirculating product refit the pump to circulation valve hose and clamp.
- (c) Relocate the bracket correctly into the rear screw and fit the pump to bowl hose & clamp, then refit and tighten the 2 front screws, once fitted ensure that the rear screw is tightened.
- (d) Dress the pump harness through the clamp on the side of the bracket and reconnect to the pump looping the harness as shown.

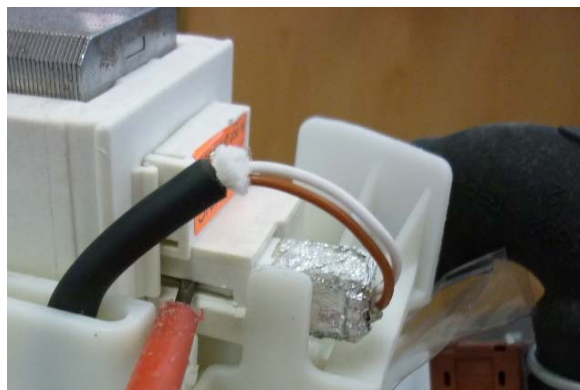

Test the drain pump operation to ensure there is no water leaks.

9 SPECIALISED SERVICE PROCEDURES

9.1 Blocked Pump Procedure Selni

It is possible to clear a blockage/obstruction from the pump without having to drain the water from the machine or disturbing the pump. If however there are concerns over the condition of the water and there may be a risk of infection, i.e. from hepatitis etc, then bail the water from the machine first.

While it is possible in some cases to be able to flick the pump from underneath the machine to remove the obstruction, our recommendation is to carry out the procedure below, which leaves the pump undisturbed.

This way the object causing the obstruction can be identified, as well as the integrity of the pump remains in tact.

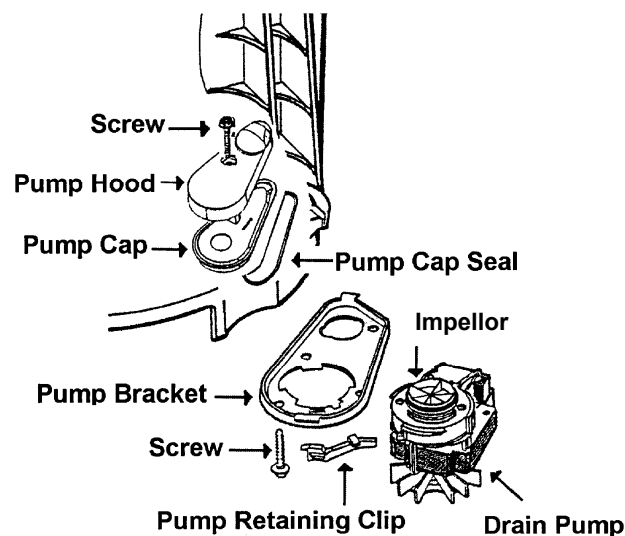

- (a) Follow the procedure for removal of pump hood. (Refer to Section 8.16).
- (b) Remove pump cap.
- (c) Locate object and check for free movement in both directions of the impellor.
- (d) Refit pump cap and pump hood, ensuring that the seal is not pinched.
- (e) If water is in the machine, enter diagnostic mode and run the pump to drain the remaining water out of the machine (Refer to Section 5.1.2).
- (f) Check for and remove any other foreign objects that may be present in the bottom of the outer bowl.

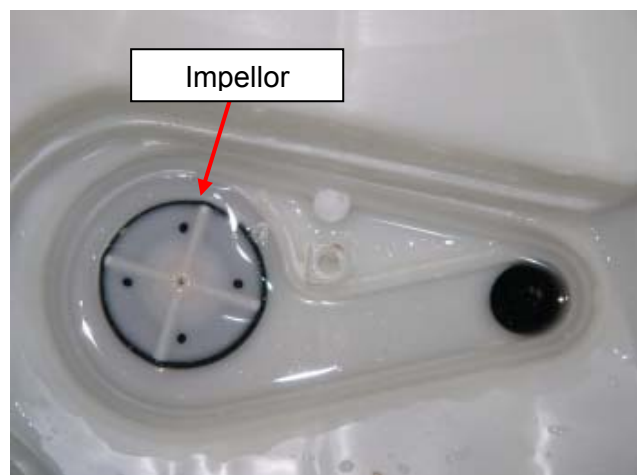

Reassembly:
Refit in reverse manner.

9.2 Blocked Pump Procedure Hanning

In the unlikely event that you encounter a blocked Hanning pump ensure that the bowl is empty before proceeding and check that the blockage is not associated with the pump cap.

- (a) Follow the procedure for removing the pump hood as per section 8.17 and check that there are no obstructions.
- (b) If clear then follow the procedure for removing the pump as per section 8.21.2
- (c) Remove the 3 screws holding the pump to the pump bracket and slide it forward and remove it from the bracket.

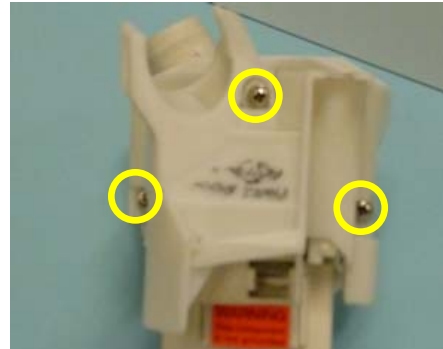

Take note of the positioning of the impeller housing before removing it from the pump.

- (d) Remove the impeller housing and clear the blockage



Reassembly:
 Refit in reverse manner.
 Checking that there are no leaks upon completion

The orientation of the pump elbow hose is critical as leaks can occur if reversed fitted. Therefore it is important if removing the elbow hose from the pump and bowl that the same ends are refitted to the pump and bowl spigots

9.3 Shaft & Bearing Replacement

Procedures described in this section as well as section 9.4 can only be carried out by using the Bearing Removal Tool Kit, part number 502009.

The contents of the kit are as follows:



Note: *The extractor mandrel was designed for the older shaft with the external thread, however will work with the shaft on this machine with the internal thread.*

- (a) Follow the procedure for Removal of Outer Bowl from the Cabinet. (Refer to Section 8.18).
- (b) Lay the outer bowl on its side before removal of the shaft. This ensures that the shaft does not fall directly onto the floor.

Note: *The shaft can only be removed towards the inside of the outer bowl. Remove the shaft. If the shaft is difficult to remove, use a puller and a mandrel. Refit the thick Stator motor clamp plate onto the outer bowl and secure with the four Stator mounting bolts. The Stator clamp plate may be used to hold the legs of the puller in place.*

SHAFT REMOVAL

STEP 1 SHAFT NUT

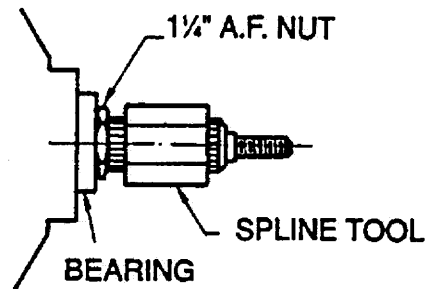

STEP 2 NOTE: EXTRACTOR NEEDED ONLY IF SHAFT CAN NOT BE PUSHED OUT BY HAND. (ECS EXTRACTOR USED & EXTENSION LEGS)

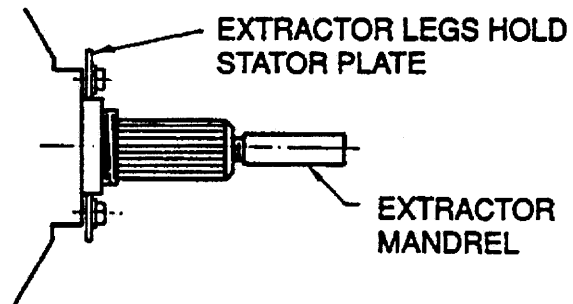

WARNING: Make sure the Stator clamp plate is flat before reusing. If in doubt, replace.

(c) Remove the outer bearing using the bearing removal tool.

WARNING: Do not remove the bearings with a hammer and drift as serious damage to the bearing housing or outer bowl may result. Use the bearing removal tool as illustrated.

(d) Remove the seal with the aid of a screwdriver handle levering from side to side.

(e) Remove inner bearing using the bearing removal tool. Insert the threaded rod and extractor washer up from the bottom of the outer bowl. Place the collar and large locating spigot on the threaded rod and extract the bearing.



BEARING REMOVAL

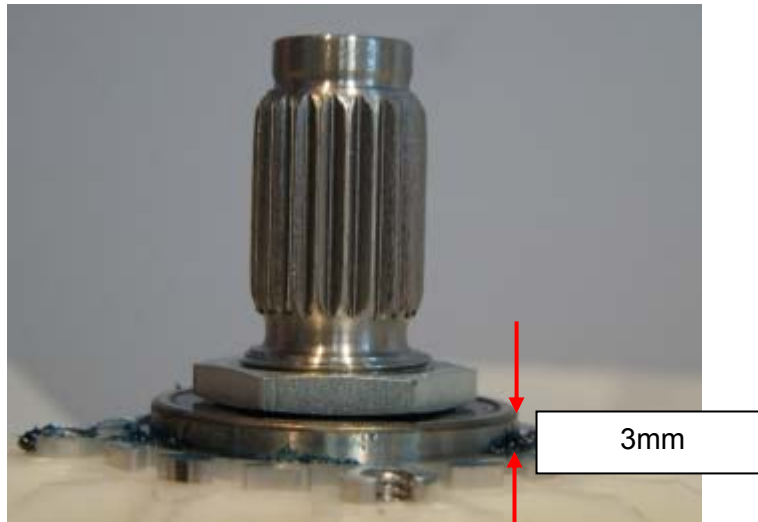
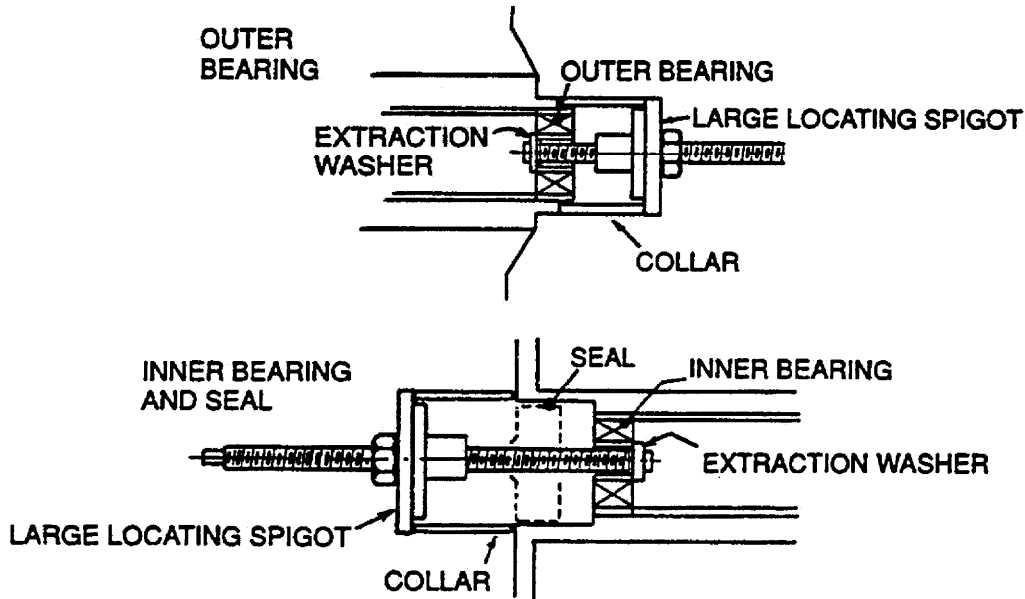

Note: The outer bearing will be proud of the housing by approximately 3mm.

9.4 Shaft & Bearing Assembly

- (a) The bearings must be inserted separately with the **inner bearing fitted first** and pulled down with the bearing tool onto the shoulder in the bearing housing.

IMPORTANT: There must be no gap between the bearing outer race and the shoulder of the aluminium extrusion. Remove the insertion tool at this point and check that the inner bearing is fully home.

- (b) Fit the bearing spacer and press in the outer bearing using the bearing tool. Check the spacer has no end float but has slight sideways movement to allow for shaft insertion.

BEARING INSTALLATION

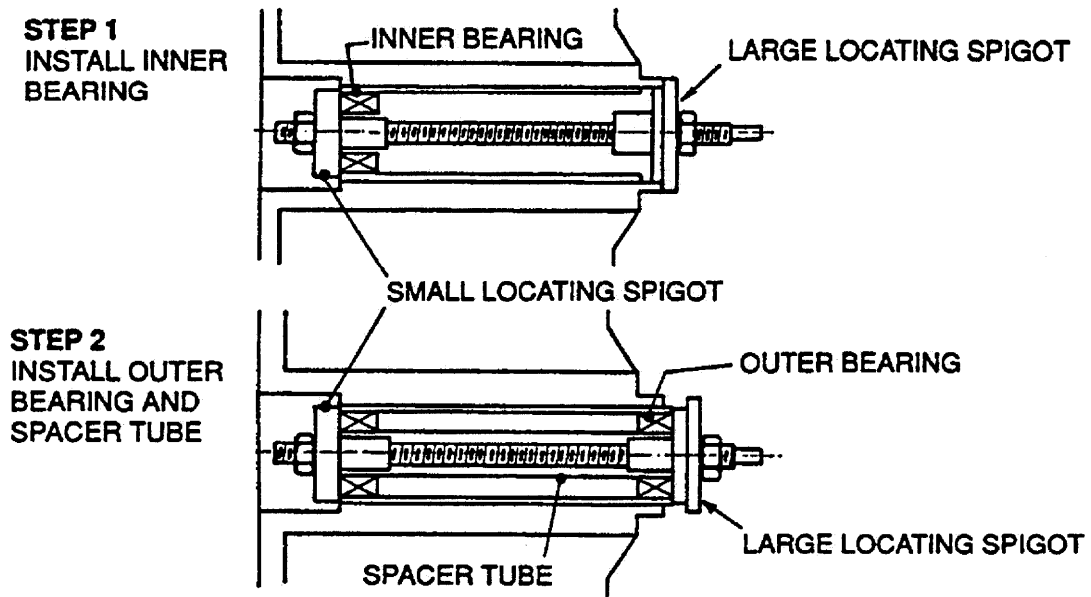

- (c) Ease the shaft through the bearings from inside the outer bowl. Take care the shaft is fitted with the threaded retaining nut section facing downwards in the direction of the base.
- (d) Fit the shaft retention nut. Use the spline tool and spanner to tighten the shaft retention nut.
- (e) Invert the outer bowl. Take care not to damage the shaft or flooring. **Fit the assembly thimble sleeve onto the shaft before fitting the seal.** Lubricate the seal outside diameter with liquid detergent and then slide into position by pressing down on both sides of the seal.

Note: *The seal should be flush with the lip on the base of the outer bowl.*

10 WASH PERFORMANCE INFORMATION

10.1 Creasing

Creasing can be caused by over loading the washer or the dryer. Permanent Press or Delicate cycles have been designed to minimise creasing as they use a lower spin speed. Do not leave wet clothes to sit in the washer or laundry basket.

10.2 Soiling

Soiling is the result of insufficient detergent for the load. White clothes are better washed separately. Separate lightly and heavily soiled items, as clothes can pick up soil from dirty wash water. Cold water below 20 °C does not wash effectively. Select the wash temperature according to soil type. For example, blood and mud are better washed in cold water, while sweat and oil based soil wash better in warmer water. Loads made up of articles of varying sizes will wash better (e.g. full loads of sheets may not wash that well). Hard water requires more detergent than soft water.

10.3 Linting

Wash lint givers, e.g. towels, flannelette sheets, separately from lint collectors (e.g. synthetic fabrics). Over loading the washer can increase the likelihood of linting. Insufficient detergent for the load can increase linting as there will not be enough detergent to hold the lint in suspension. Over drying synthetic fabrics in a dryer can cause a build-up of static electricity and result in the fabrics attracting lint.

10.4 Detergent Residue

Over loading the washer can result in detergent residue being caught in the creases of the fabrics. If this occurs, decrease the load size. Some detergents need to be pre-dissolved. Check the instructions for the detergent. Cold ambient temperatures, cold washes or short agitation times may not let the detergent dissolve properly. In these cases pre-dissolve the detergent. Overdosing of detergent can also cause residue when foam breaks down and will show as white specs on the clothing. Poor quality detergents can result in residue.

10.5 Black Marks on Clothes

A build up caused by the interaction of fabric softener and detergent (scud) can flake off and mark clothes. Do not use too much fabric softener, maximum 75cc. If this is a problem, it is recommended that the machine is periodically filled with hot water, plus 1-2 cups of dishwasher powder and left to soak.

10.6 Grey Marks on Clothes

Not enough detergent for the amount of soil on the clothes can result in grey marks on clothes. If this is a problem it is recommended that the machine be periodically filled with hot water, plus detergent and left to soak.

10.7 Dye Transfer

Wash and dry non-colorfast clothes separately. Non colorfast clothes left sitting in a washer or laundry basket can transfer dye to other clothes.

10.8 Tangling

Washing with too much water (i.e. under loading) can cause the clothes to tangle around each other. Do not load the machine by wrapping clothes around the agitator.

11 OPERATING PROBLEMS

11.1 No Power

If the machine appears dead, and there is no response from pressing the power button, then check the following.

- Check the supply voltage and that the machine is plugged in and switched on.
- Remove the lid and the console.
- With the power supply isolated, physically check all the plug connections to the Motor Control Module.
- With the power supply switched, on check all voltage readings as described in section 5.8.
- Prior to replacing a Motor Control Module, check all resistances of the components as described in section 5.9. We also recommended that a visual inspection of the motor and pump area be carried out. Check for corrosion and signs of water leaking as well as damage that may have occurred to any of the wiring harnesses.

11.2 Flooding / Leaking

- Check for obvious signs of leaks from taps, inlet hoses, inlet washers and water valves. There should be no signs of water within the top-deck area.
- Check for obvious signs of leaks in the standpipe; drain hose, pump, and air bell. The pump can leak if the pump bracket is not secured properly.
- Check that the drain hose is inserted correctly, and that the drain is not blocked, or pushed too far into the standpipe.
- Check that the water valves are not jammed on, or dripping when off.
- Has the pressure tube been connected when the bowl contained water? The pressure tube must be connected when the bowl is empty, otherwise flooding may occur on the next cycle.
- Has the machine oversudsed, caused by too much, incorrect use of or poor quality detergents.
- Has the correct water level been selected for the clothes load? Too much water for the clothes load will cause water to splash.
- Check that the size setting is correct.
- Check that the high water level is acceptable. Acceptable limits are 10-110mm from the top of the agitator to the water. If it is less than 10mm, then splashing may be a problem. Empty the bowl, remove then refit the pressure tube to the Motor Control Module, and then. If water levels are outside these limits, replace the Motor Control Module.
- Otherwise it could be that the machine was overloaded or in a humid environment. Too much detergent could have been used.
- Check that when the machine is draining that the Recirculation valve is not by-passing to recirculation and is closed in the drain position.

11.3 Noisy

If the user is complaining about noise, it may be in a number of different areas. Is the noise during spin? Is it a banging sound? This would typically be the drain hose, inlet hoses, mains lead or harness. If it is an out of balance noise, check that the machine is level and stable. Check the bias spring and balance rings. Remove the inner bowl and check that its weight is within specification (Refer Section 2.13).

If it is a 'clunk' that occurs up to 3 times per cycle, this would be a bowl check and is completely normal. This occurs when the machine is draining and is $\frac{3}{4}$ empty. This is a 'feature' and a noise that cannot be reduced.

Other things to check are:

- Is the machine level and on all four feet equally.
- Feet inserts fitted in the feet & corner cabs are clear of the floor.
- Check the mains lead, inlet hoses and drain hose outside the wrapper, behind the machine.
- Check the harness and drain hose inside is not banging on the wrapper during spin.
- Check the bias spring is fitted correctly.

421827

- Check that the 2 balance rings in the inner bowl contain water. Check the bowl weight.
- Check for noisy suspension rods.
- If the inner bowl or agitator is noisy, check for obstructions. Check the spline drive is clean. If there is a grating sound, check the single stainless steel washer beneath the spline drive.
- If the motor is abnormally noisy, chipped or cracked Rotor magnets are unlikely to affect the noise.
- If the pump is noisy, check for obstructions. Change parts as necessary.

11.4 Continuous or Slow Spinning

The most likely cause of slow or continuous spinning is 'Out of Balance'. To correct this, refer to section 5.6.5.

Too much detergent can cause final spin to stop and re-spin 4 times. This is due to suds build up between the inner bowl and outer bowl, and normally will sound a User Warning.

A more likely cause of slow spinning is the **Hot Bowl Flag** (Refer to Section 5.1.6).

11.5 Siphoning

Typically this occurs when the Standpipe height is too low. The minimum is 850mm from the floor. This is 90mm ABOVE the drain hose outlet on the machine. With a very low standpipe and a very high water level, this could result in water pouring down the standpipe prior to the machine completing fill and resulting in no water in the bowl during agitate.

If the drain hose is pushed too far into the standpipe or drain, the machine will siphon during rinse, which could result in a 'No Taps' user warning.

Siphoning can result from a restricted drain hose or partial pump block.

NOTES