

**Fisher & Paykel**

**Service Manual**

# CLOTHES DRYER

## MODELS

**AD55 – ED55 – ED56**

220/240 Volt 50 Hz

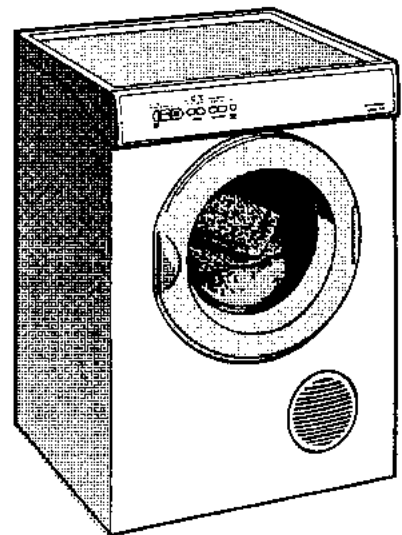
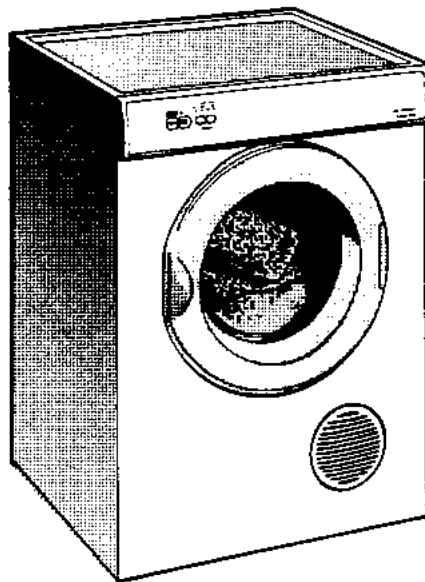
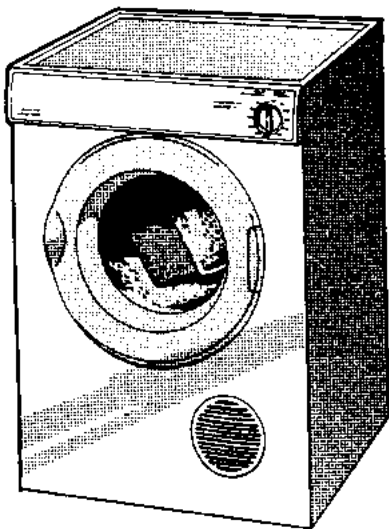

### **Fisher & Paykel Appliances Ltd**

78 Springs Road, East Tamaki, Auckland  
PO Box 58-732, Greenmount, New Zealand  
Telephone 64 9 273 0660  
Facsimile 64 9 273 0637

**517644**

September 1995

COPYRIGHT © FISHER & PAYKEL LTD 1995

# NOTES

# DRYER SAFETY

Correct installation is very important for all dryers, for maximum efficiency and safety.

**For Electronic and Dualcare Dryers** make sure the air outlet has been either:

- Externally vented or
- Internally vented with Vent Deflector fitted. (refer Installation section for venting options)

**For Compact Dryer**

- Fit the plastic spacers provided. This ensures the air inlet is not up against the wall (refer Installation section).
- Minimum clearance needed from the wall is 50mm.

The lint produced in the drying process can become a fire hazard if it is allowed to accumulate in or around the dryer.

Accumulated lint can also reduce the efficiency of the dryer, causing longer drying times, which increases power consumption.

- Never run the dryer unless the airflow system is free from obstruction.
- Clean lint filter before every load.
- Ensure the area round the dryer is clear of lint.
- At regular intervals have the interior of the dryer cleaned of any accumulated lint. This must be done by a qualified person for electrical safety.
- This dryer has been designed for domestic use only, not for commercial applications where there may be increased lint accumulation or flammable materials in the atmosphere or clothes load.
- The air inlet of the dryer must be kept clear at all times.
- Use the dryer to dry fabrics washed in water only.
- Do not dry garments soaked in dry-cleaning fluid or clothes that have been washed with any flammable solution.
- Never dry rubber articles, fibreglass, or any plastic items or film e.g. plastic lined tablecloths and baby's bibs.

# GENERAL SPECIFICATIONS

## Dimensions (mm)

Width 568  
 Depth 550  
 Height 790

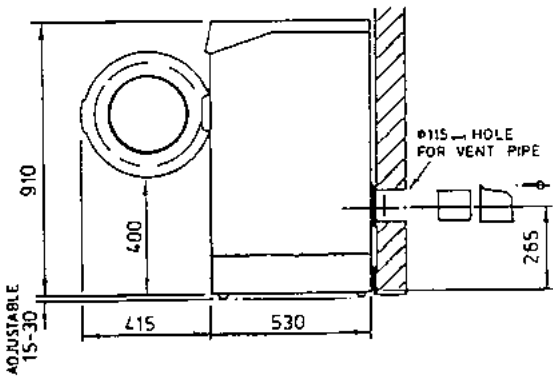
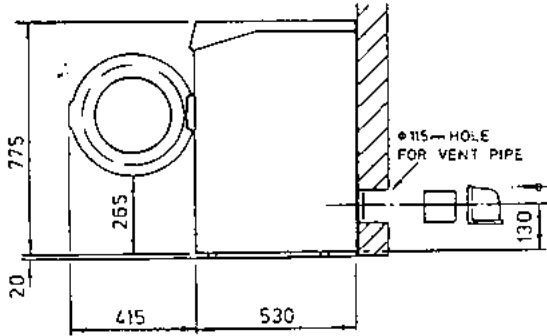
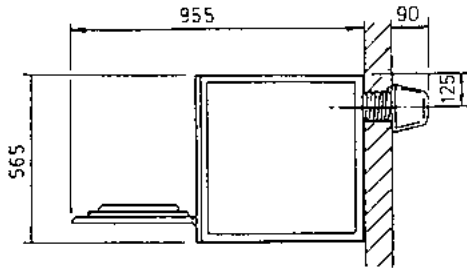

## Packed Weight

36 kg

## Control

AD55 – Electro/Mechanical Timer  
 ED55/56 – Electronic Timing & Sensing

## Capacity

4.5 kg dry weight

## Electrical

230/240V.AC 50Hz 8 amp approx.  
 Heater 1750 watts approx.  
 Motor 130 watts approx

## Thermostat:

**Heater Plate** cut-out 73°C approx  
 reset 58°C approx

**Exhaust Duct (if fitted)**  
 (AD55 only) cut-out 95°C  
 manual reset

# GENERAL DESCRIPTION

These dryers employ a patented pressurised cabinet system. A fan draws air through the air intake grille pressurising the cabinet. The pressurised air passed through the clothes in a revolving drum. Damp air passes out through the lint filter, which traps excess lint, then out via the exhaust duct at the rear of the cabinet.

## INSTALLATION

Four installation options make the dryer versatile enough to suit most requirements.

### 1. Free Standing

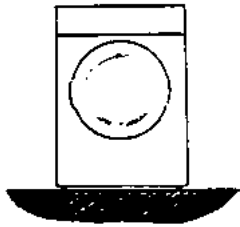

The dryer stands on the floor and can easily be moved into position.

### 2. Side by Side Match \* Electronic & Dualcare only

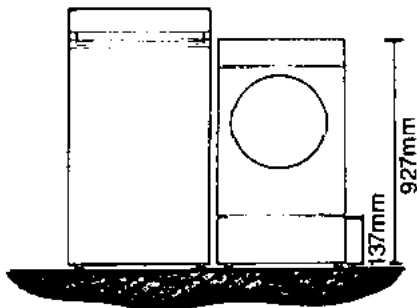

A plinth with adjustable feet makes the dryer an attractive side by side match to an existing washer. It will also minimise the amount of bending required when loading or unloading the dryer.

### 3. Inverted Wall Mounting\* ALL Models

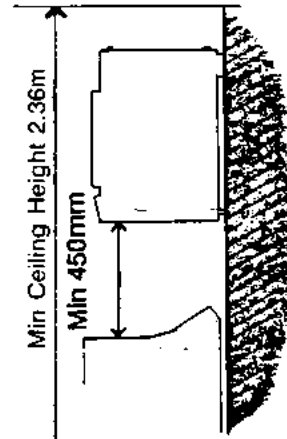

A wall mounting kit and inverted panel makes installing the dryer above a washer or tub possible.

### 4. Upright Wall Mounting\* ALL Models

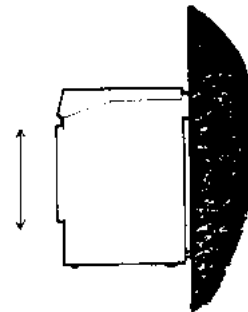

The wall mounting kit allows you to install the dryer at any desired height minimising the amount of bending and stretching.

\* Kits for these options are available from any F&P dealer along with instructions.

#### Kit Part Numbers

AD55 – 502074  
ED55 – 502075  
ED56 – 502076

## OUTSIDE WALL MOUNTING INFORMATION

When mounting dryer on an outside wall, use the following diagrams to determine position of mounting breaking and vent hole.

**NOTE: Read these instructions in conjunction with venting instructions.**

PARTS SUPPLIED		
QTY	DESCRIPTION	PART NO
1	WALL MOUNTING BRACKET	460913
2	SPACERS	460912
2	SCREWS No 8 x 20	611944
1	INVERTED CONTROL PANEL	

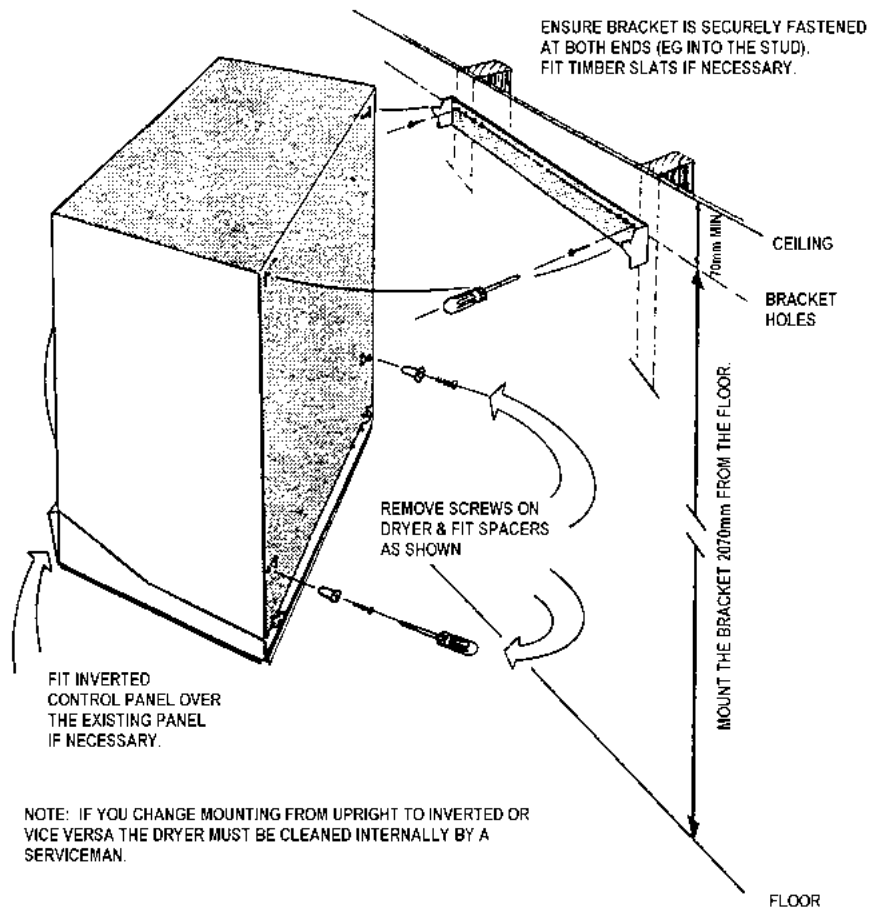

NOTE: IF YOU CHANGE MOUNTING FROM UPRIGHT TO INVERTED OR VICE VERSA THE DRYER MUST BE CLEANED INTERNALLY BY A SERVICEMAN.

TOOLS AND PARTS REQUIRED (Wooden Wall)	
1	Drill and 3mm bit
1	Phillips screw driver
2	Wood screws 14 x 50 timbertite screws. (wooded wall)
1	Wood screw driver
1	Helper to lift dryer onto bracket.

TOOLS REQUIRED (Concrete wall)	
1	6 mm bit
2	M6 x 50 expanding bolts
1	Adjustable spanner

### PROCEDURE

1. Determine dryer position on wall and mark required bracket position  
Note: If you are venting dryer through the mounting wall ensure resulting hole clears studs.
2. Fit bracket to wall ensuring fixing engagement to studs for wooded walls using wooded slat if required.  
Note: fit dummy slat to wall for spacers if a mounting slat is used.
3. Fit spacers with long screws provided.
4. Mount dryer on bracket. Tilt out from below, engage bracket in back panel slots then lower and reset against wall. You will need help to do this.

## INSTRUCTIONS

When mounting dryer on an outside wall, use the following diagrams to determine position of mounting bracket and vent hole.

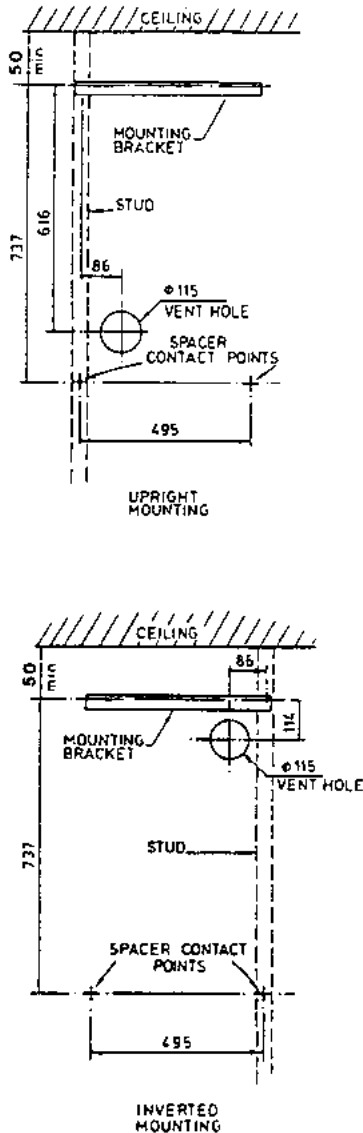

## CAUTION

If the installation is changed from upright to inverted or vice versa the inside of the dryer cabinet should be cleaned out of any lint build up. When the dryer is in use, lint can build up inside the dryer, on the bottom panels. When the position of the dryer is changed this lint can fall into the drum or onto the element and result in a potentially hazardous situation. We advise that this lint can fall into the drum or onto the element and result in a potentially hazardous situation. We advise that this lint be cleaned away before the position is changed. This operation requires the

removal of the rear panel. This should be done by a competent serviceman.

## VENTING

A number of venting options are available.

**NOTE:** The ED55/56 Dryer has been designed for best performance when one of the following venting methods is used. The dryer **SHOULD NOT** be used without either the vent deflector vent kit or exhaust hose.

### External Venting –

The dryer has been designed to be externally vented to provide these following advantages:

- Ensures optimum efficiency by preventing recirculation of moist air.

The dryer operates by taking dry cool air, heating and circulating it through the clothes. If the intake air is already moist then it will reduce the drying effect when it is circulated through the clothes

- Eliminates condensation on walls and ceilings.

A normal load of wet garments (3-5 kilograms) can easily have 100% moisture content by weight (i.e. 3-5 kg). This equivalent to 3-5 litres of water which will be vented out of the dryer during the drying process. This water, if vented into the room, will condense onto the walls, ceilings and sides of any other appliance including the dryer.

- Reduces the chance of lint being sucked into the dryer.

The exhaust from the dryer will cause airflow in the Laundry area disturbing lint, dust and fluff to be stirred around and possibly into the dryer air intake. This lint etc can then be distributed through the clothes.

- Fine lint particles, which aggravate respiratory allergies, are removed from the room.

Very fine lint particles can pass through the lint filter and out the exhaust system

and into the room. Note: It is very important to always use the lint filter even if you are venting the dryer outside. The dryness sensing systems is tuned to obtain best results when a lint filter is fitted. Removing the lint filter will result in reduced performance as well as all the lint being exhausted into the room.

Three external venting options are available.

**a) Flush Venting**

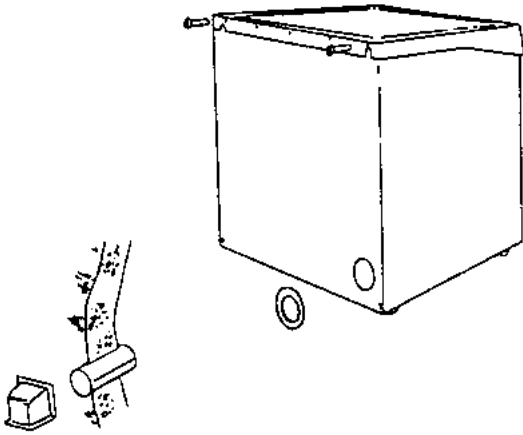

The dryer is vented via a galvanised metal pipe through a hole in the wall. This is suitable for floor and wall mounted dryers. If the venting hole is to be drilled through a wooden framed wall, we recommend that the hole be lined with a metal tube. This stops moisture and fine lint from accumulating in the wall cavity.

Also if garments washed in flammable solvents are placed in the dryer a fire could result. The flames will exhaust through the vent and possibly into the wall cavity.

A weather cap should also be used on the outside wall to stop wind and rain from entering the room. A venting kit is available (P/N 319120).

**b) Moveable Venting**

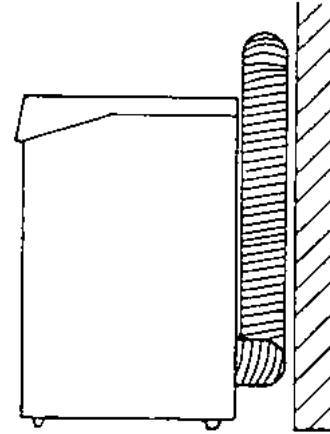

As for Flush Venting but a flexible hose allows the dryer to be moved from the wall slightly. Suitable for floor mounted dryers only.

A 2 meter flexible hose is available (part number 460130) The hose screws into the exhaust duct at the rear of the dryer.



c) **Window Venting**

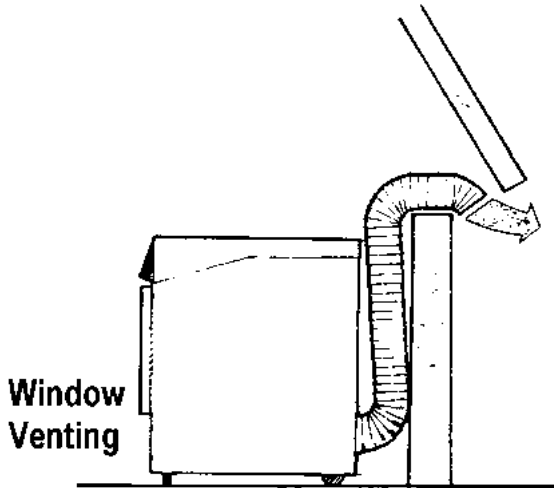

A flexible hose is used to vent the dryer through a window. Suitable for floor mounted dryers only.

**Internal Venting -  
Internal Venting -**

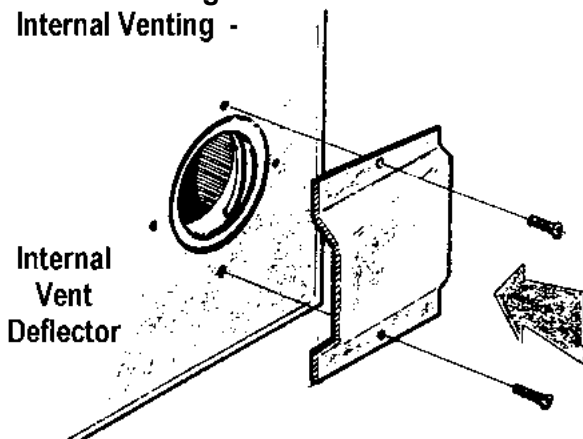

The dryer is provided with a vent deflector which screws on to the back of the dryer over the exhaust outlet. **THE DEFLECTOR MUST BE FITTED IF EXTERNAL VENTING IS NOT POSSIBLE.** The deflector also prevents the dryer from being pushed against the wall and restricting the airflow.

**Custom Venting**

A vent system up to 5 metres long using no more than 3 right angle bends of at least 80, diameter galvanised metal pipe.

**External Venting**

All external-venting systems should be

Made from galvanised metal pipe or be sleeved with a galvanised metal pipe where the vent system goes through a wall or ceiling.

Exhausted outside and not into another confined space.

Fitted with a cap outside to stop rainwater entering the dryer exhaust system and angled to avoid condensation running back into the dryer.

DO NOT use internal Vent Deflector as a weather cap as this will cause airflow restriction and loss in performance

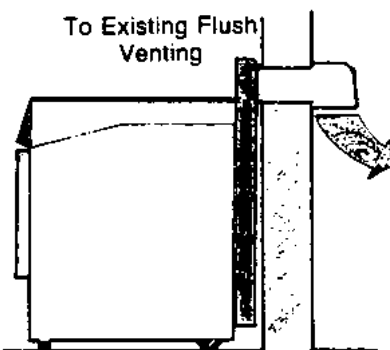
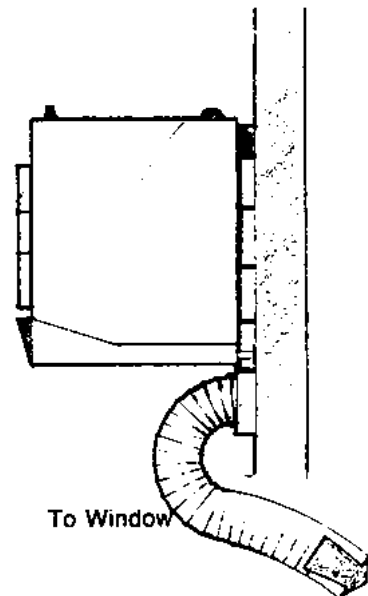

**Venting Duct to Existing Flush Venting**

Options shown can be for both inverted or upright dryers.

# CLOTHES CARE

## Sorting –

In most cases the clothes will go straight from the washer into the dryer, so it is just not practical to resort the laundry after it has been washed. Generally, articles that have been washed together can be dried together. But it can make things easier if, when sorting laundry for the washer, you bear in mind the best clothes mix for the dryer.

In order to achieve both optimum drying performance and efficiency, clothes should be sorted for the dryer according to how long they take to dry. The simplest way to do this is to sort the wash into two categories:

1. The heavier garments that take longer to dry, e.g.: towels, t-shirts, flannelette sheets.
2. The light garments that dry quickly e.g.: cotton/polyester shirts, sheets etc, synthetics.

By sorting the clothes in this way, you are:

- Separating lint givers from lint collectors.
- Ensuring against uneven drying by collectively treating garments that take similar times to dry.
- Minimising drying times because you aren't overdrying some items while others are still damp.

This is perhaps the simplest way to organise the washing; however, there are other ways:

- You may wish to separate your delicates and synthetics to take advantage of the low temperature cycles, e.g.: Delicate on the Dualcare dryer.

Many people enjoy the benefits of utilising a dryer to dramatically decrease their ironing. This is achieved by laundering all permanent press articles separately. The tumbling action and heat of a dryer removes the wrinkles from these garments, so if they are hung on a clothes hanger as soon as the dryer cycle is completed, they require little or no ironing.

## Loading –

- Clothes for tumble drying should be spun at the highest spin speed the autowasher will allow for the load type. The more water you remove in the wash the less you have to remove in the dryer. Never put dripping wet garments in the dryer.
- By closing zippers, hooks and eyes etc, you can prevent clothes from being snagged or tangled.
- To ensure clothes are dried evenly, shake them out and load them individually.
- For optimum efficiency load the dryer to allow enough room for the clothes to tumble freely. This will ensure adequate airflow and minimise creasing.

## Drying Small Loads – Electronic models.

When very small loads i.e. 1 or 2 shirts are placed in the ED55/56, the control system may stop the dryer before the garments are correctly dried. This is due to the exhaust air not passing through the load fully, hence the temperature of the exhaust air is much the same as any empty or dry load. The control system will therefore stop prematurely.

Rather than drying single garments, it is recommended that a number of additional garments are loaded in as well. All garments will then come out correctly dried.

# AD55 OPERATING INSTRUCTIONS

## Dualcare (AD55) Dryer

The Dualcare Dryer has been designed so the temperature inside the dryer is kept to a minimum throughout the cycle. This means that the clothes are dried at about the same temperature you would wash them. Just as too high wash temperatures can damage garments, excessive temperatures in the dryer should be avoided to ensure optimum clothes care.

The Dualcare Dryer offers the choice of two cycles differentiated by the amount of energy or heat used for drying.

- The traditional **Regular Cycle** for drying more resilient fabric or garment types, e.g.: cotton. Here the heater remains on until the last 13 minutes of the cycle where the dryer goes into Cool down. During cool down the drum tumbles and the fan blows cool air through the clothes to remove the last bit of moisture gently without heat. This also makes the garments more resistant to creasing if left in the dryer.
- A special **Delicate Cycle** where the heater pulses on and off. The result being the energy input is considerably lower, so garments are dried at lower temperatures for better care of synthetics or delicates. The Delicate Cycle consists of three drying phases. The energy input is successively decreased as the timer proceeds through each phase. This means that when the clothes are at their wettest they are subjected to more heat than when they are dryer and more susceptible to damage.

As with Regular, the Delicate cycle is terminated with a 13 minute cool down period.

## Using the Dualcare (AD55)

- Plug dryer cord into wall socket and switch on.
- Load clothes in Dryer.
- Clean lint filter.
- Turning the knob clockwise only, select the desired cycle and drying time.
- Try to remove the garments from the dryer as soon as the cycle is completed. This will help prevent creasing.

## Drying Times

With a new dryer it may take a few trials before the customer can accurately predict the correct drying time for each individual load. As a guide we have included some example loads and their drying times. These times will, of course, be approximate figures only, based on the garments being subjected to a high-speed spin at the end of their wash.

Load Comparison	Approximate Drying Time
7 Towels	60 – 80 mins
10 Shirts (cotton / polyester)	20 – 40 mins
5 T shirts plus 5 Towels	60 – 80 mins
9 small delicates	20 – 30 mins

## Flammable Solvents –

Only use the dryer to dry fabrics washed in water. **NEVER** put garments soaked in dry cleaning fluid or clothes that have been washed with any flammable solution in the dryer. Vapour from the inflammable solution could be ignited on the heater element of the dryer resulting in a fire.

**NEVER** dry rubber articles, fibreglass, plastic bags or film.

## ED55/56 OPERATING INSTRUCTIONS

The electronic dryer can sense when the clothes are dry, taking the guesswork out of choosing drying times. When the dryer senses that the clothes are at the level of dryness selected, it will automatically finish the Drying Cycle. The dryer will run for a minimum of 5 minutes. This allows the dryer cabinet and drum to heat up to a stable temperature. During which time the dryness sensing temperatures are ignored.

The cycle times for the ED 55 and ED56 dryer on the regular setting are a minimum of 5 minutes to a maximum of 150 minutes. Whilst on the ED56 dryer on the low setting the cycle times are from a minimum of 5 minutes to a maximum of 250 minutes. These are the maximum times the dryer will run for if the load is too large, too wet or the lint filter is blocked.

After the Drying Cycle a ten minute Cool Down or Airing cycle commences. During the Airing Cycle the drum tumbles, blowing cool air through the clothes to help prevent creasing. At the end of the Airing Cycle the Dryer will beep for 15 seconds to tell you that the clothes are ready.

Start	5 minutes minimum
Drying Cycle	Reverses every 8 minutes
	150 max ED55/56 Reg. Cycle 250 max for ED56 low temp cycle
Airing Cycle	10 minutes
Crease Guard (option) ED56 only	12 hours - reverses every 5 minutes

### Power Supply & Connection -

The ED55/56 is designed for 230V ac 50Hz operation. When the dryer is connected to a power outlet, power is always supplied to the

Control. The ON/OFF switch on the ED55/56 simply tells the control to switch the LEDs off and wait, in a standby mode, for the next command. The ON/OFF button does not isolate the dryer from the mains supply.

The ED55/56 Dryer can either be left connected to the mains supply or switched off at the wall socket or unplugged after each use. However, if the dryer is disconnected from the power the dryness setting in the memory will be lost. When the dryer is switched on again it will return to the mid dryness setting.

### Using the Electronic Dryer –

- Plug cord into wall socket and switch on.
- Load garments into Dryer (see Loading)
- Clean lint filter
- Press POWER button to turn Dryer on.
- Select Dryness level.
- Select Temperature setting (ED56 Dryer only)
- Press START/PAUSE button to start the Dryer.
- Try to remove the garments from the dryer as soon as the cycle is completed, or use the crease guard option (ED56 Dryer only). This will prevent creasing.

### Dryness Levels –

The ED55/56 have five Dryness levels indicated by the LED's on the control panel.

**These LED's DO NOT indicate time intervals, but indicate a degree of dryness the clothes will reach before the ED55/56 Dryer will switch off.**

The ED55/56 will switch off when the required dryness level is reached. The time required to reach the selected dryness will depend on the size of the load, how wet the load is to start with, the types of fabrics, how

the garments are loaded, as well as the condition of the lint filter and the venting system.

The higher the dryness setting selected, however, the longer the dryer will take to reach that level of dryness.

The Dryness Sensing System detects the average dryness level, hence load consisting of a mix of different types of fabric may well result in some garment coming out of the Dryer at different dryness levels. Sorting the load will result in a more consistent dryness level throughout your load.

The display shows 2 LED's for some dryness settings e.g. Light –medium dry and Medium – extra dry.

The light to medium settings are for drying delicate fabrics and fabrics prone to shrinking e.g. synthetics, sweatshirts. The medium to extra dry settings are for heavier, durable garments which require longer drying times e.g. towels, flannelette sheets.

### **1 Hour Setting**

The 1-hour setting is a manual cycle, which dries continuously for 60 minutes. The manual cycle does not sense when the clothes are dry.

If you wish to dry shoes in the dryer we recommend you use the manual cycle, as the auto-sensing function cannot sense when shoes are dry. It is important to check the shoes throughout the manual cycle to avoid overdrying.

### **Temperature Settings ED56 only**

Your ED56 Dryer has 3 temperature settings – regular, low and cold.

**Regular** for drying most fabrics.

**Low** for drying delicates and synthetics. It is half heat so the temperatures are lower for maximum care of the fabrics. The low temperature uses less power but will take longer to dry than regular.

**Cold** is an airing cycle to freshen up garments. The cold setting operates only on the 1-hour manual cycle. The low and high settings will operate on both the manual and the auto-sensing cycles.

If the dryer is left connected to the power it will remember the last dryness setting

selected. If the dryer is disconnected from the power, the mid dryness setting will be selected when the dryer is used again.

### **Airing**

After drying to the selected dryness setting, a special airing cycle circulates cool air through the clothes for a final 10 minutes to reduce creasing.

In the **ED56** this cycle is indicated by the temperature setting LED changing to **COLD**. During the drying cycle an airing can be selected by pressing the temperature button.

If the dryer is **PAUSED**, or the door is opened during the airing cycle, the dryer will automatically turn off.

The ED56 can be manually programmed into the airing cycle at any time after the initial 5 minutes of drying by pressing the **COOL TEMPERATURE** setting. Once selected, the cool cycle cannot be cancelled.

If the ED56's **COOL** is selected prior to pressing the **START**, the 60-minute cool cycle will be run.

### **Pause –**

Opening the door or pressing the START/PAUSE button will stop the dryer tumbling. To start again close the door and press START/PAUSE. If the dryer door is left open for more than 8 minutes the dryer will switch off.

### **Key lock**

Once you have selected the drying programme and have started the dryer you can lock in the programme using the key lock option. This prevents the dryer from being accidentally switched off, or the programme being altered. The key lock can also be used to prevent children turning the dryer on.

1. Press LOCK button and hold for 2 seconds.
2. The key lock LED will flash and the dryer will give 2 quick beeps.
3. The key lock LED will remain on and all other keys will now be locked.

To remove the key lock repeat steps 1 and 2.

### **Delay Start – ED56 Dryer Only**

The delay start option can be used to delay the start of the drying cycle. This is

particularly useful if you have reduced rate nighttime electricity.

1. Press POWER button.
2. Select Temperature and Dryness level, and Crease Guard if required.
3. Press DELAY START button, once for 3 hours delay, twice for 6 hours, 3 times for 9 hours, a further press will cancel the delay start and a longer beep will sound. Selecting delay start will cancel the "beeping" at the end of the cycle. The delay start will not operate when the 1-hour manual cycle is selected.

### **Crease Guard – ED56 Dryer only**

To minimise creasing when the cycle is finished, by using the Crease Guard.

At the end of the drying cycle the drum will rotate briefly every 5 minutes blowing cool air through the clothes. The dryer will beep to remind the customer that the clothes are ready. The crease guard will continue for 12 hours or until the dryer is turned off. Crease guard can be selected anytime during the programme by pressing the CREASE GUARD button.

To restart the dryer simply press the POWER button.

### **DRYER RACK (P/N 460667)**

The Dryer Rack teams up with the dryer to facilitate the drying of those items, which do not benefit from being tumbled. Place shoes or hats on the stationary rack, the dryer drum rotates and warm air is circulated in around the items. The open structure of the rack allows the maximum amount of air to come into contact with the damp articles.

#### **Using the Dryer Rack –**

1. Open the dryer door.
2. There is a locating pin at the back of the dryer rack, pin end first into the dryer, locating the pin into the hole at the centre back of the dryer drum.
3. The dryer rack will hang below the centre hole and sit level across the door opening.

#### **Dryer Shoes and Hats –**

1. Avoid putting dripping wet shoes or hats in the dryer. Most articles can be spun out in your washer to rid them of excess water.
2. In the ED55 Dryer the maximum dryness level that should be used. More than one cycle may be required to dry the article to the desired level of dryness. In the ED56, selected the 1 hour setting
3. Place shoes sole side up or on their sides with the toes pointing towards the door. This will ensure that they are subjected to the maximum amount of warm air.
4. If shoes have laces, these should be removed and tongues pulled up.
5. Lay hats flat on the rack. Use the same settings as when drying shoes.

## SPECIAL FEATURES

### Attention Getter –

The ED55/56 is fitted with a feature mainly intended to be used in shop displays etc, to draw attention to the Dryer. This feature consists of a regular flashing of the LED's on the control panel.

To activate the ATTENTION GETTER feature –

1. Plug ED55/56 into power socket and switch socket on.
2. Press and hold the LOCK button, then press the POWER button.

The LED's will then start flashing.

To stop the display.

1. Turn the dryer off at the power socket.

The display will stop and the dryer is ready for normal operation.

The ED55/56 can be left in the ATTENTION GETTER mode indefinitely. It will simply keep on repeating the cycle. No damage will result if the dryer is kept in this mode for long periods of time.

### Fault Modes –

Should a fault develop in the Electronic Control system of the ED55/56 the control panel will display a particular pattern on LED's as well as a continuous sounding of the buzzer.

If this should occur, first turn the dryer off at the power socket or unplug the dryer. Retry the dryer.

# SERVICE PROCEDURE

## AD55

**WARNING:** Before dismantling this dryer, remove 3-pin plug from wall outlet socket.

## ED55/56

**WARNING:** Before attempting to service or adjust any part of the machine, disconnect the electrical power supply from the wall outlet.

The console power switch DOES NOT isolate the mains voltage from the machine.

**ELECTROSTATIC DISCHARGE SENSITIVE DEVICES:**



Any competent bearing the above label is subject to damage by electrostatic discharge while being handled. Care must be taken when handling the parts to prevent accidental contamination.

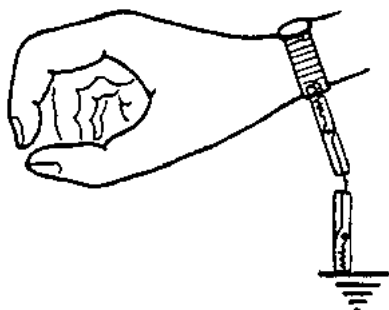

Use anti static wrist strap

GROUNDING  
TO EARTH

Printed circuit boards removed from the machine for return must be protected from possible

electrostatic damage (ESD) while in transit by the use of specialised packaging provided.

## Stage A – To Remove Timer Knob (AD55 only)

1. Grip firmly and pull forward. Note: Push fit only
2. Replace by matching flat on the timer shaft to corresponding flat in knob insert. Push firmly into place.

## Stage B – To Remove Control Panel

Complete Stage A then –

With the door closed

1. Remove one screw from either side of panel concealed on underside.
2. Open door – remove remaining screw located in control panel above door.
3. Tilt panel forward from lower edge. Pull down gently.

**NOTE:** Panel has 6 retaining lugs along the top edge to locate it to trim.

Reassemble to reverse order.

## Stage C – To Remove Top trim

Complete Stages A & B then:

1. Remove 2 screws from front of trim previously concealed by panel.
2. Remove 5 screws from rear of trim.

Reassemble to reverse order.



## Stage D – To Remove Back Panel

1. Remove 21 screws from around the edge of back panel.
2. Remove 2 screws from the middle of the panel.

**NOTE:** It is not necessary to remove exhaust flange.

Reassemble in reverse order.

## Stage E – To Remove Top Cabinet Panel

Complete Stages A, B & C then:

1. Remove 10 screws from top edge of panel.
2. Panel can now be removed.

Reassemble in reverse order

## Stage F – To Remove the Drum

Complete Stages A to E then:

1. Remove wires connecting element and thermal overload cutout.
2. Remove earth lead from element carrier.
3. Provide a suitable floor covering to protect door and front of cabinet from being marked. Then lay dryer on its front.
4. Take off the belt tension from the drum at the jockey pulleys – remove belt from motor pulley.
5. Remove 4 screws that hold elements carrier to sides of cabinet.
6. Pull the drum away from the front of the cabinet.
7. Refit in reverse order. Ensure that the drum belt is over the drum before assembly.

Check felt seal.

## Stage G – Replacement of the Front Drum Bearings

**NOTE:** This can only be done with the drum removed.

Complete Stages A – F then:

With the cabinet standing upright:

1. Remove 7 screws that hold the bearing support ring to the air duct.
2. The bearing ring can be removed from the air duct.
3. There are 6 drum bearings fitted to this ring.
4. When replacing drum bearings, check the bearings' surface on the front edge of the drum to ensure it is free from grease, rough surfaces etc.

Reassemble in reverse order.

## Stage H – To Remove Front Bearing Holder and Air Duct Assy and Felt Seal

Complete Stages A – G then:

1. Remove air duct tube from front air duct assy. Just pulls off.
2. Remove 7 screws that hold air duct assy to the front of the cabinet.
3. Duct can be pulled away from the front of the cabinet.
4. The felt seal can be fitted to this duct assembly instiu after the front bearing holder has been removed.

Reassemble in reverse order, taking care to ensure that the air duct gasket fits around the edge of the duct and does not fold over when fitted to the cabinet.

## Stage I – To Remove the Motor

With the back panel and drum removed as in Stages D and F then:

1. Loosen 2 motor mounting saddles at each end of the motor, which can then be removed.
2. The motor can then be lifted away from the motor mounts enabling access to the motor wiring, motor switch block, capacitor and resistor.
3. Motor wiring harness terminals may then be disconnected from the motor.

**NOTE:** The terminal numbers to the wiring harness colours.

## Stage J – To Remove the Fan

Complete Stages D, F& I then:

The fan is held on to the motor shaft by a fan boss on which the fan is clamped.

1. Remove 4 screws that hold the fan flange disc to the clamping disc behind the fan.
2. The fan may now be removed from the boss.
3. The fan boss can then be removed from the motor shaft by loosening the Allen key set screw on the fan boss.
4. Then withdrawing the boss from the shaft of the motor.

Reassemble in reverse order.

## Stage K – To Remove the Motor Driving Pulley

The Motor Driving Pulley is held on the shaft by a roll pin through the pulley and motor and also by Allen key set screw.

1. Drive out the roll pin that fits through the pulley and shaft. This may be done with a pin punch.
2. Loosen the Allen set screw on the motor pulley.
3. The pulley can then be withdrawn from the motor shaft.

Reassemble in reverse order.

**NOTE:** The Motor Pulley fits the motor at the terminal block end of the motor. The Fan Boss fits the motor at the opposite end to the motor terminal block (long end of the motor shaft).

## Stage L – To Remove Jockey Pulley

Complete Stage D then –

1. Remove the tensioning spring between the two jockey pulley arms.
2. The Jockey Pulley arms can be removed from the base of the cabinet by straightening the bent tabs on each arm.
3. Access to these tabs are under the base of the cabinet.
4. After straightening, the arms can then be withdrawn by holding them to one side of the slot and lifting the other edge from the slot.

Reassemble in reverse order.

**NOTE:** The Jockey Pulley arms and rollers are at two different heights. The longer of the two arms/rollers fit closest to the cabinet side.

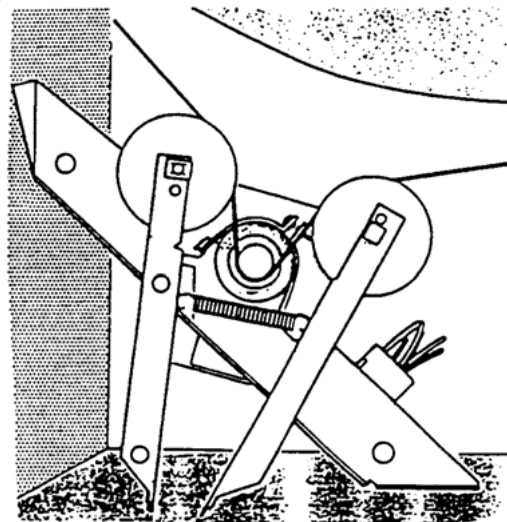

## **Stage M – To Remove Timer (AD55 only)**

Complete Stages A, B C & E then:

1. Remove 2 screws securing timer to front of cabinet.
2. Wiring can now be removed from timer terminations.

Reassemble in reverse order.

## **Stage N – To Remove Electronic Module (ED55/56 only)**

Use wrist strap and take standard ESD precautions.

1. Complete Stage B
2. Gain access to module fixing screw by moving protective covering.
3. Disconnect sensor plugs.
4. Disconnect wiring harness.
5. Remove three lower retaining screws holding module to control panel.
6. Remove three upper nuts holding module to control panel.
7. Module may now be withdrawn.

Reassemble in reverse order.

## **Stage O – To Remove the Door Assembly**

1. Open door fully.
2. Remove 2 screws retaining door hinge cover, which can now be removed.

3. Support door with one hand, then remove screw retaining lower hinge.
4. Door assembly may now be lifted off top hinge. Note the location of spacer washers.

Reassemble in reverse order.

## **Stage P – To Remove Door Switch**

1. Open door fully.
2. Remove 2 screws retaining door hinge cover, which can now be removed.
3. Remove 2 screws retaining door micro switch cover, which can now be removed.
4. Disconnect wiring to door micro switch – it can now be removed.

Reassemble in reverse order, adjusting location of switch clamp. Supply to motor must be off when door opening is more than 40 – 65mm.

## **TOOLS & EQUIPMENT - (AD/ED 55/56)**

- Ampere Meter (10-amp max) or Watt meter. (2000 watt max)
- Multi Meter with voltage range up to 250 V ac and resistance range up to 300 ohm.
- Philips No.2 screwdriver.
- 6mm socket.
- Long nose pliers.
- Anti static wrist strap.

# AD55 WIRING DIAGRAM

COPR. © 1987 Fisher & Paykel Ltd.

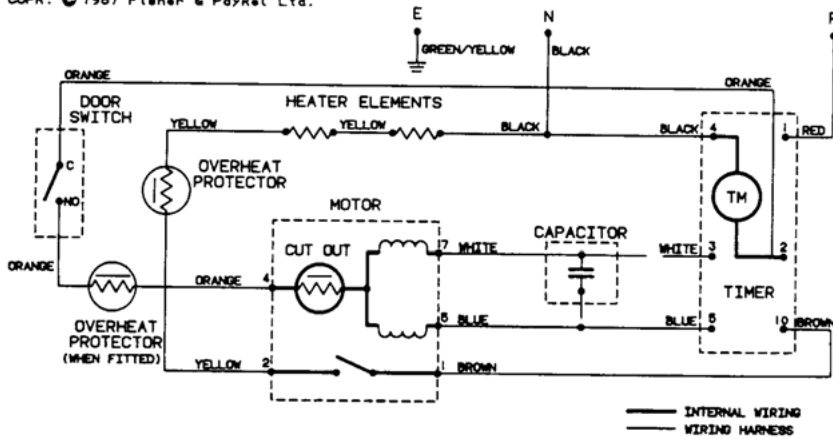

FOR USE ON 240 VOLT 50 Hz 3 PIN WALL SOCKET  
CAUTION: TO SERVICE MACHINE POWER MUST BE DISCONNECTED

PART No. 460538 C

# AD55 DRYER SEQUENCE CHART

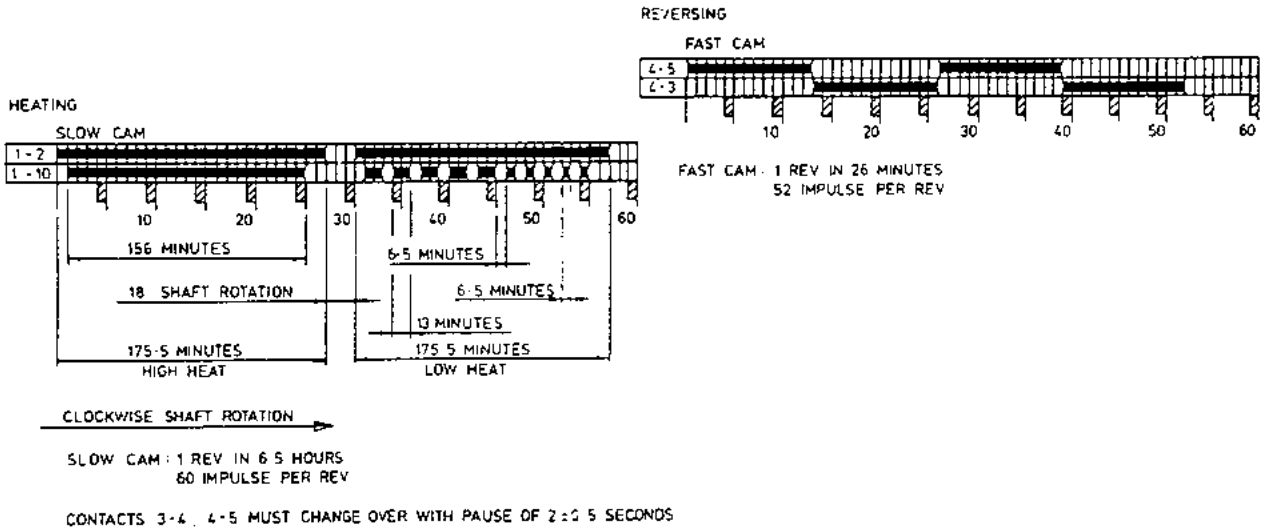

# ED55 WIRING DIAGRAM

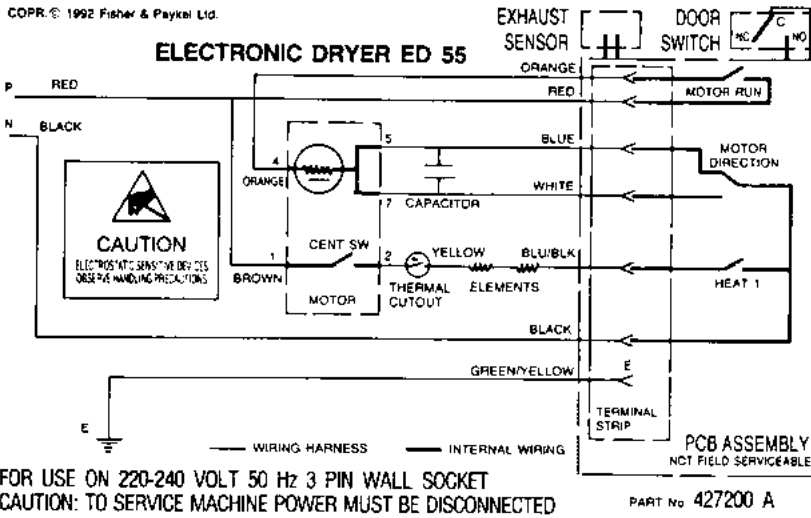

# ED56 WIRING DIAGRAM

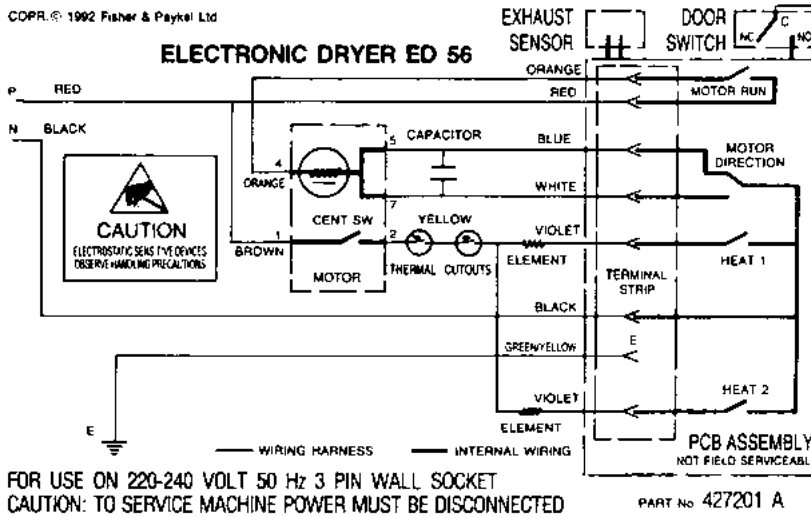

**Note:**

AD/ED55 elements are connected in series, using (6.3mm) wide spade terminal connections.

ED56 elements are connected in parallel, using narrow (4.8 mm) spade terminal connections.

# REMOVAL AND HANDLING

## E.S.D –

Static Electricity is known to us all by the occasional electronic shock felt when leaving a car or the annoying “static cling”. This same phenomenon known as Electrostatic discharge (ESD), can seriously damage electronic components. The voltages required to damage electronic components are much lower than those, which can be felt by humans.

Like all Electronic Assemblies, the ED55/56 PCB Assemblies are susceptible to damage due to ESD. Some basic handling procedures must be followed to reduce the risk of damage due to ESD.

1. The PCB Assemblies must be transported and stored inside the bag and box they were supplied in.
2. When handling the PCB Assemblies use an earth strap attached to the dryer you are working on. These earth straps are available from Customer Services.

## Packaging & Transportation –

The ED55/56 PCB assemblies are sent in a black or dark coloured plastic bag. This is not a normal plastic bag but a special bag designed to protect the PCB against ESD. The box has been designed to offer maximum protection against physical damage to the PCB assembly.

Whenever the ED55/56 PCB assemblies are transported they must be packaged in the bag and cardboard box. **FAILURE TO DO SO MAY RESULT IN CANCELLATION OF YOUR CREDIT.**

## Connectors –

The ED55/56 has 10 connections onto the PCB Assembly. 8 via the terminal strip mounted adjacent to the transformer, plus two connectors located on one edge of the PCB.

Three types of connectors will be used on the ED55/56 Dryer.

1. **Standard Flag Terminal:** These can be identified by clear plastic insulator. These will be used for early production. Care must be taken when applying and removing them from the PCB terminal block. **DO NOT USE EXCESSIVE FORCE ON THE PCB.** If necessary, the terminals can be removed by using a pair of long nosed pliers and levering the terminals off using the relays as a pivot.
2. **Positive Lock:** They can be identified by the hard plastic insulator. These terminals are designed for easy application and removal. These connectors lock on to the terminal. To remove the connector the insulator must be gripped. **DO NOT TRY TO REMOVE THE TERMINAL BY PULLING AT THE WIRE.**

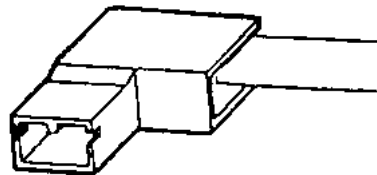

3. The connectors used for the exhaust sensor and the door switch harness have to be gripped by the locking tabs on each side of the connector. **DO NOT** pull on the wires when trying to remove the connector. These connectors will only fit on one way. Do not try and force it on incorrectly.

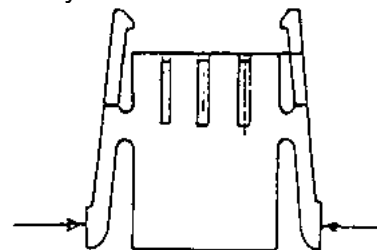

## ELECTRONIC MODULE CONNECTION CHECK

The following is a quick test procedure to check that the electronic module is correctly wired to the dryer and that the dryer is operating correctly.

### A. LED & BUTTON TEST

1. Press and hold LOCK, then press > DRYNESS so that both buttons are down at the same time.  
- All LED's should be on:

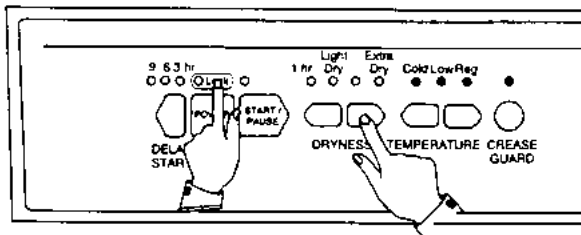

2. Press ON/OFF button to turn LED's off.
3. Press ON/OFF button and check all other buttons are working. Check that buzzer is sounding.

### B. DRUM ROTATION & ELEMENT CHECK

1. Connect an amp meter or watt meter in the mains supply to ED55/56. Turn dryer on and set to REGULAR temperature, then press START/PAUSE button to start.

Amp meter should read approx 8.5 amps OR watt meter should read 2000 watts.

**Note 1:** If dryer does not start, check the door switch adjustment. See "Other Fault Codes" under FAULT CODES.

**Note 2:** A fault on the circuit board will cause a fault code to be displayed on the Dryness LED's about 12 secs after the initial pressing of the START/PAUSE button – overwriting the "NORMAL" display – see FAULT CODES.

2. Press START/PAUSE button twice.
  - Dryer should stop and reverse direction.
  - Amp meter should again read approx 8.5 amps OR watt meter should read 2000 watts.
3. Press START/PAUSE and set to LOW temp setting. Press START/PAUSE.

4. Press START/PAUSE and set to Cold and run again.  
Meter should read approx 0.5 amps or 130 watts.

### C. EXHAUST SENSOR & DOOR SWITCH TEST (Not available on all models)

1. Start dryer running REGULAR or LOW TEMPERATURE mode; then press and hold LOCK; then press START/PAUSE button.

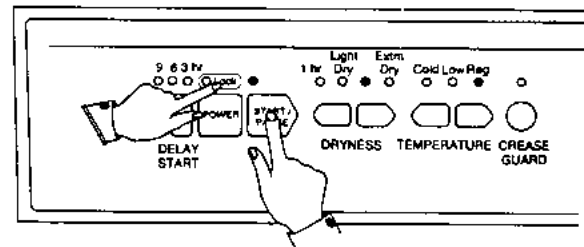

**Note:** This advances the drying cycle so that a shorted temperature sensor can be detected. (See Fault Codes – Shorted Exhaust Sensors).

2. Press and hold LOCK; then press < DRYNESS. Release and press START/PAUSE.

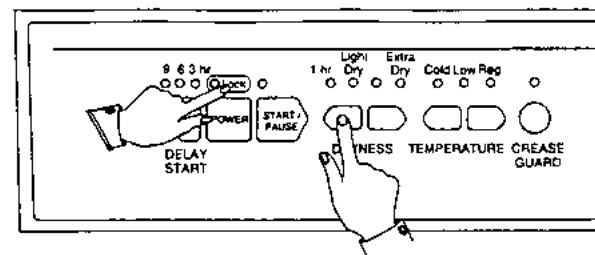

- If there is a fault with the exhaust sensor, the fault code will be immediately displayed within 1 second with the beeper sounding (see fault codes).
3. Open the door and the machine should pause. (The three delay LED's will turn on with the door opened). ED56 only

**END OF TEST**

## FAULT CODES

If a fault should develop in the temperature measurement system of the ED55/56 control system, a fault code will be displayed on the front panel.

A fault code is distinguished from normal display in that only a combination of the 4 dryness LED's will be on and with the beeper sounding on and off.

If a fault code should appear, first switch the dryer off at the wall socket or remove the plug. Switch on again, if fault re-occurs use the following codes to diagnose the fault.

**NOTE:** Pressing the POWER button will clear the fault code.

The faults and their respective fault code that can be checked and serviced in the filed are as follows:

### Faulty Exhaust Sensor –

**Code:** 0101 pr 1001

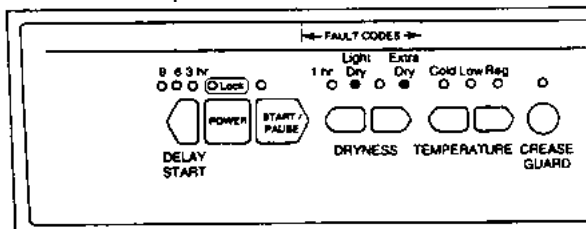

OR

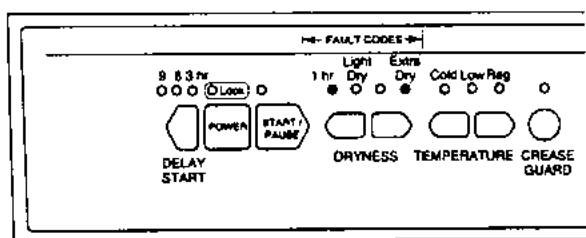

**Action:**

- Unplug exhaust sensor. Check resistance of sensor. (See Testing Exhaust Sensor). If faulty, replace.

**NOTE:** A shorted exhaust sensor can also be sensed by the Temperature Measurement System as a very low temperature reading. Remember the sensor decrease in resistance as the temperature decreases. To stop a

fault code showing at very low temperatures (below 0°), this fault code will not show until 5 minutes after the dryer has started. This allows the sensors time to be heated up by the exhaust air. up by the exhaust air.

Refer **EXHAUST SENSOR AND DOOR SWITCH TEST** to eliminate this delay.

### Exhaust Sensor Shorted to Cabinet:

**Code:** 1010

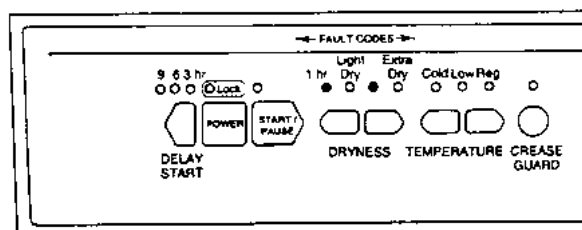

**Action:**

- Unplug exhaust sensor. Check resistance between sensor wires and the dryer cabinet. There should be no connection between the wires and the cabinet.
- If there is a short, inspect the exhaust sensor harness to trace the cause of the short.

### Over Temperature

**Code:** 1101

**Cause:** If the exhaust air temperature is above 90°C a fault code is given. The dryer should not reach this temperature in normal operation.

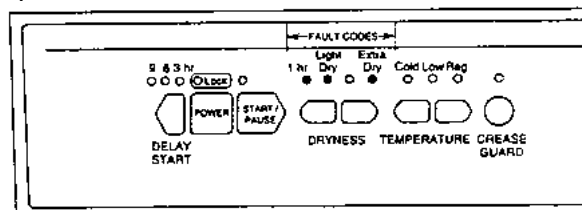

**Action:**

- Check the lint filter and exhaust duct for any blockage or restriction to the airflow.



## Faulty Exhaust or Ambient Sensor

**Code:** 0110

**Cause:** The sensors are either open circuit or shorted.

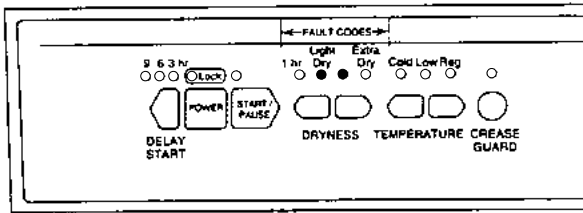

### Action:

- Unplug the exhaust sensor. Check the resistance of the sensor. (See Testing Exhaust Sensor). If faulty, replace. If the ambient sensor is faulty, the electronic module will have to be replaced.

## Over Temperature

**Code:** 1101

**Cause:** If the exhaust air temperature is above 90°C a fault code is given. The dryer should not reach this temperature in normal operation.

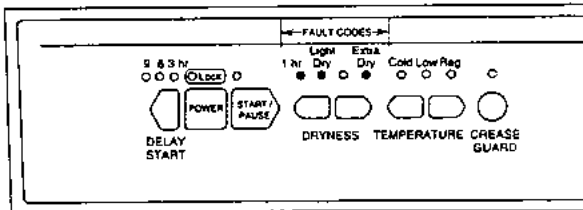

### Action:

- Check the lint filter and exhaust duct for any blockage or restriction to the airflow.

## Brown Out

**Code:** 1111

**Cause:** The product has experienced 8 brown outs within 60 seconds and has aborted the cycle and displayed this fault.

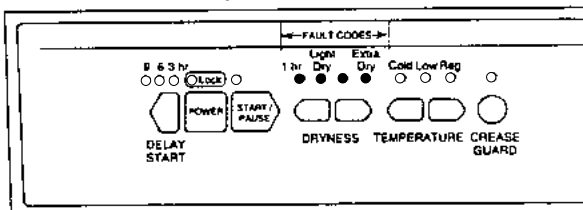

### Action:

- Check the supply voltage. If the supply voltage drops below 180 volts this fault will occur.

## Other Fault Codes –

There are many other fault codes, these refer to faults on the PCB assembly itself. The PCB assembly will have to be replaced in these cases.

Record the fault code displayed and return with the PCB assembly to Fisher & Paykel for repair.

## TESTING THE EXHAUST SENSOR

At normal room temperature (25°C) the resistance of the thermistor will be approx 2000 ohm and at 0°C 1640 ohms.

### Description –

The Exhaust Sensor consists of a device called a thermistor, which is mounted on a small piece of PCB attached to the wiring harness.

Use a multi meter to test the resistance of the sensor.

The thermistor is a device that changes its electrical resistance according to the temperature. The higher the temperature, the higher the resistance thermistor.

## DOOR SWITCH ADJUSTMENT

The door switch should be adjusted so that the door has opened no more than 40 mm – 65 mm before the PAUSE mode is activated and the dryer stops.

Adjust door switch by removing hinge cover (two screws). Loosen two screws holding the switch.

If the door switch is not activated the ED55/56 will sound a warning tone when the START/PAUSE button is pressed.

## BROWN OUT

If the mains voltage falls below a certain voltage, even for a short period of time, it is known as a brown out.

If this mains voltage falls below this minimum voltage the Electronic Control System will not be able to function correctly. The Electronic

Control System therefore is fitted with a circuit that will automatically turn the dryer off.

The voltage at which this happens is between 165 – 170 volts.

During Brown Out the dryer will simply switch off. The dryer can be restarted by simply using the POWER button.

## TEMPERATURE MEASUREMENT (Not available on all models)

With the ED56 it is possible to display the temperatures the exhaust and ambient sensors are measuring. The temperature of each sensor can be displayed using the following procedure:

Start the dryer as per normal operation, i.e.

1. Press POWER button.
2. Press START/PAUSE button.
  - Dryer will now be operating normally.
3. Press & hold LOCK then press < DRYNESS button at the same time.

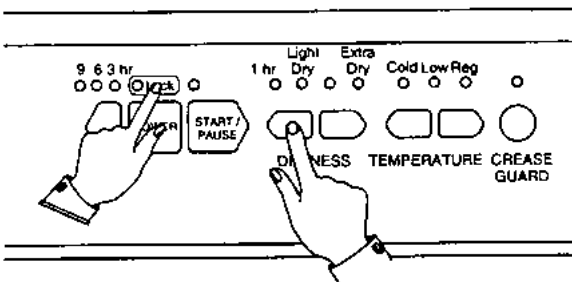

The display will now change to display the temperature of the exhaust sensor. The temperature is displayed in c coded form (**see Reading Temperature Display**).

4. Press < DRYNESS button again.
  - The display will now show the temperature of the Ambient sensor, again this is in coded form.

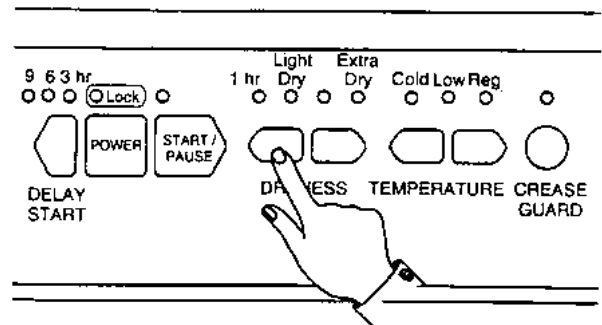

5. Press > DRYNESS button to change the display back to showing the exhaust sensor temperature.

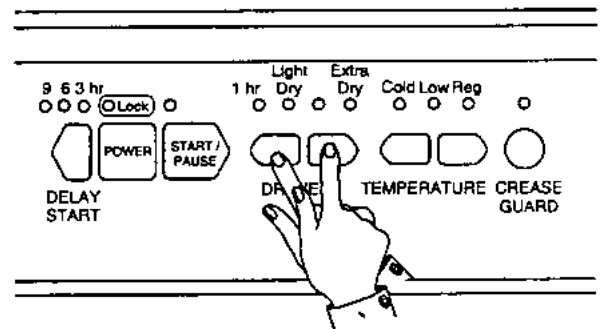

6. When either of the two dryness buttons are pressed either the ambient or exhaust sensor temperature will be displayed.
7. Press POWER button to return to normal operation.

**NOTE:** Throughout the temperature reading mode the dryer will continue as normal.

# READING DISPLAYED TEMPERATURE

(Not available on all models)

The temperature is displayed using the binary code on 8 LED's on the control panel, i.e. from 1 hr through to Crease Guard.

Each LED represents a certain temperature. For each LED that is turned on it's corresponding temperature is added together to give a total. This total is the temperature (in degrees C) that the sensor is reading.

The temperatures corresponding to each LED is as follows:

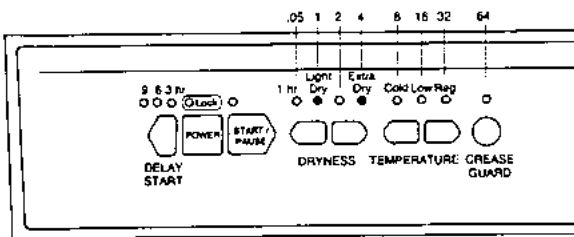

## Example One

After selecting the temperature measurement mode the following is displayed:

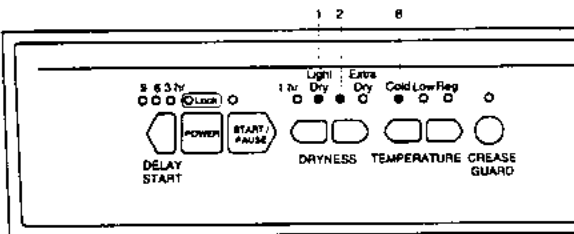

Add the temperatures corresponding to each LED which is on

$$1 + 2 + 8 = 11$$

Hence the temperature is 11 degrees C.

## Example Two

After selecting the temperature-measuring mode the following is displayed:

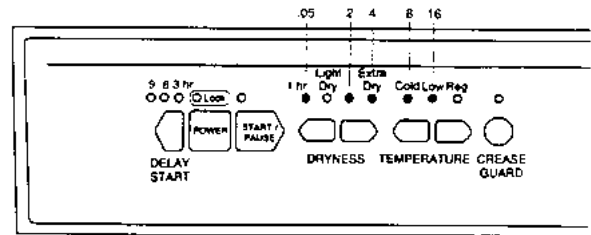

Add the temperatures corresponding to each LED which is on

$$0.5 + 2 + 4 + 8 + 16 = 30.5$$

Hence the temperature is 30.5 degrees C

**NOTE:** In the temperature reading mode, the temperatures are updated approximately every 1/2 second.

The final drying temperature of the previous drying cycle will remain latched in memory until the START/PAUSE of the next drying cycle is pressed. This applies to the ED56 only.

## COMMON DRYING PROBLEMS

<b>PROBLEM</b>	<b>POSSIBLE CAUSE</b>	<b>SOLUTION</b>
Creasing	Overloading	Ensure clothes have sufficient room to tumble freely.
	Leaving load in the dryer	Try to be there to remove clothes from the dryer as soon as the cycle has finished.
	Spinning too fast	Choose a lower spin speed in autowasher.
Lint Transfer	Inappropriate sorting	Try to dry items that produce lint, toweling, separately from synthetics. Dry dark items together.
	Blocked lint filter	Clean your lint filter every time you use your dryer.
	Too much static	Use a fabric softener or tumbler pad.
Tangling	Poor loading	Load each item separately
	Drying stockings, ties & belts	Try placing these items in a net wash bag or pillowcase when tumble drying them.
Uneven drying	Inappropriate sorting	Separate heavier items, e.g.: towels, t-shirts, etc from lighter garments, e.g. cotton/polyester shirts, sheets etc.
	Overloading	Always allow enough room for the clothes to tumble freely.
Stiff fabrics	Overdrying	Try selecting a shorter drying time.
	Inadequate rinse	Ensure clothes are properly rinsed.
Shrinkage	Inappropriate sorting	The combination of heat and tumbling action of a dryer can cause shrinkage in some garments, particularly woollens. Check your care labels before drying items in your dryer.
	Inappropriate cycle or time	If in doubt always dry garments on the "Delicate" cycle where they will be subjected to lower temperatures. Try to dry for the minimum time possible.